

MHI
Copy 3

FM 11-150

WAR DEPARTMENT FIELD MANUAL



PHOTOMAIL OPERATION

FORM 11-150 (Rev. 1-15-45)

WAR DEPARTMENT • APRIL 1945

WAR DEPARTMENT FIELD MANUAL
FM 11-150

PHOTOMAIL
OPERATION



WAR DEPARTMENT • APRIL 1945

United States Government Printing Office
Washington: 1945

WAR DEPARTMENT

Washington 25, D. C., 20 April 1945

FM 11-150, Photomail Operation, is published for the information and guidance of all concerned.

[AG 300.7 (15 Sep 44)]

BY ORDER OF THE SECRETARY OF WAR:

OFFICIAL:

J. A. ULIO

Major General

The Adjutant General

G. C. MARSHALL

Chief of Staff

DISTRIBUTION:

AAF (5); AGF (5); ASF (2); T of Opns (5); Base Comd (5); Island Comd (5); Gulf Comd (5); Dept (5); Arm & Sv Bd (2); Def Comd (2); Tech Sv (2); SvC (5); PC&S (1); PE (5); Gen & Sp Sv Sch (10); USMA (50); A (5); CHQ (5); D (2). T/O & E: 11-597 (3); 12-601, Base Post Off (DA-FA) (3).

Refer to FM 21-6 for explanation of distribution formula.

CONTENTS

	<i>Paragraph</i>	<i>Page</i>
CHAPTER 1. GENERAL	1-11	1
CHAPTER 2. ORGANIZATION AND OPERATION.		
<i>Section I.</i> Photomail organization	12-14	4
<i>II.</i> Photomail technical operation.....	15-22	7
CHAPTER 3. TRAINING.		
<i>Section I.</i> General	23-26	10
<i>II.</i> Specialist training	27-45	11
<i>III.</i> Team training	46-70	26
CHAPTER 4. OPERATING PROCEDURE.		
<i>Section I.</i> Army postal section.....	71-82	36
<i>II.</i> Official photomail	83-85	41
<i>III.</i> Signal Corps V-mail laboratories.....	86-92	44
<i>IV.</i> Message center procedure.....	93-97	51
<i>V.</i> Sending department	98-101	63
<i>VI.</i> Receiving department	102-114	66
INDEX		74

CHAPTER I

GENERAL

1. Purpose and Scope

The purpose of this manual is to prescribe routine methods for signal photomail service, to serve as a guide for training personnel charged with signal photomail duties, to furnish commanders and their staffs with information concerning the functions and capabilities of signal photomail, and to standardize the operation of photomail teams.

2. Definitions

a. PHOTOMAIL. Photomail is the process of microphotographing official documents or personal messages on rolls of 16- or 35-mm film, and forwarding the rolls after development to a receiving station in the approximate area to which the photographed official documents and personal messages are addressed. Individual facsimiles, or prints of legible size, are made from the miniature negatives and are delivered to the addressees.

b. V-MAIL. V-mail is photomail applied to personal correspondence. The term *V-mail* is an abbreviation of *victory mail*.

c. OFFICIAL PHOTOMAIL. Official photomail is photomail applied to official communications and documents of the War Department and of those agencies, the transmission of whose photomail is approved by the War Department.

3. Comparative Weight and Size of Photomail

a. COMPARATIVE WEIGHT. The use of photomail reduces the bulk and weight of mail handled by approximately 98 percent.

b. SIZE OF FACSIMILES. The V-mail facsimile is approximately one fourth the size of the original special letter sheet form. The official photomail facsimile is approximately the same size as the original document.

4. Use of V-Mail

a. OFFICIAL ATTITUDE. The use of V-mail rather than regular mail between foreign theaters and the continental United States should be encouraged. Commanding officers should inform person-

nel under their command of the advantages of V-mail for personal correspondence.

b. DELIVERY ASSURANCE. Delivery of V-mail letters is expedited and assured. The original letter is not destroyed until the facsimile has been satisfactorily reproduced by the receiving V-mail laboratory. If a regular letter is unavoidably destroyed en route, a permanent loss is suffered. A V-mail letter, however, can be reproduced again and forwarded.

5. V-Mail Priority

Every effort is made to transport V-mail by air. In certain instances, however, letters written on V-mail forms cannot be micro-filmed because of the absence of V-mail facilities. In instances where V-mail facilities are not available, letters written on V-mail forms are given preference in handling and are forwarded by air whenever possible in their original form. Letter mail for destinations outside the continental United States is transported by air in the following order of precedence: (1) Official air mail. (2) V-mail. (3) Regular air mail. (4) All other mail weighing not in excess of 2 ounces.

6. V-Mail Forms

Personal messages of military personnel require the use of a special letter sheet form measuring 8½" x 11" which is available, free, to the armed forces. Commanding officers outside the continental United States should make certain that adequate quantities of V-mail forms are available throughout their commands. Individuals who are not in the armed forces can obtain V-mail forms without charge from any United States post office or by purchase from a commercial printer.

7. Operational Responsibility

The over-all operation of the photomail service is the responsibility of the Army Postal Service of The Adjutant General's Office. The operation of an oversea photomail service is the responsibility of theater or base commanders.

8. Technical Responsibility

The Chief Signal Officer of the United States Army is responsible for the design, development, specification, compilation, maintenance, storage and issue, technical supervision and operation of the necessary photographic equipment, training of personnel for the operation of such equipment, and the procurement of necessary commercial facilities, including the administration of contracts for such facilities for the photomail service.

9. Censorship

V-mail sent from members of armed forces at oversea points will be censored by their respective company officers or other designated officers before sealing. The letter should be indorsed to show censorship on both inside and outside of the V-mail sheet form. V-mail originating in the United States is handled by the local post office in the routine manner and forwarded to the proper V-mail station. The letter is submitted for censorship at the V-mail station, prior to microfilming.

10. Assignment

V-mail stations are initiated and maintained whenever an oversea area receives a volume of mail requiring such an installation and when trained personnel and equipment are available.

11. References

- AR 380-5, Safeguarding Military Information.
- AR 850-65, Miscellaneous, Storage and Handling of Nitrocellulose Film in United States Army Establishments.
- FM 12-105, The Army Postal Service.
- TM 1-219, Basic Photography.
- TM 11-2300, Enlarger PH-542/UF (V-mail).
- TM 11-2301, Densitometer PH-326.
- TM 11-2302, Paper Cutter PH-513/GF (V-mail).
- TM 11-2304, Projector PH-543/UF (V-mail).
- TM 11-2305, Developing Machine PH-512/GF (V-mail).
- TM 11-2313, Light Meter (V-mail).
- TM 11-2309, Reader PH-284 (V-mail).
- TM 11-2395, Electronic Timer (Photrix Model 1528).

CHAPTER 2

ORGANIZATION AND OPERATION

Section I. PHOTOMAIL ORGANIZATION

12. General

Installations for handling the processing of photomail are organized differently for the continental United States and oversea installations. These differences are as follows:

a. CONTINENTAL UNITED STATES. In the continental United States, the photographic processing of V-mail is normally handled by commercial concerns. This is accomplished by contract with the Federal government. The War and Navy Departments have entered into an agreement for maintaining accounting records and paying for services rendered in processing V-mail.

b. OVERSEA INSTALLATIONS. In oversea installations, the processing of photomail for the War Department will be accomplished by a combination of Army Postal Service and Signal Corps personnel. Processing of photomail for the Navy Department will be accomplished by Navy Postal Service. V-mail for Army personnel will be handled by the Navy controlled V-mail service in the absence of Army V-mail installations and vice versa. To facilitate delivery, Navy V-mail is normally separated from Army V-mail.

13. Army Coordinating Agencies

The Army Postal Service and the Signal Corps are active participants in handling photomail. Both are responsible for performing sending and receiving operations. (See fig. 1.) V-mail laboratories which perform photographic processing of photomail are under the direction of the Signal Corps and cooperate closely with the associated Army post office section. The combined V-mail laboratory and Army postal section is known as a V-mail station and is a detachment of a base post office installation.

14. V-Mail Detachments

The organization of a V-mail detachment at a base post office will be determined by the volume of photomail to be handled and the amount of personnel involved. The V-mail detachment will be comprised of teams prescribed by section II of T/O & E 12-601, Base

ALL V-MAIL STATIONS
PERFORM BOTH FUNCTIONS

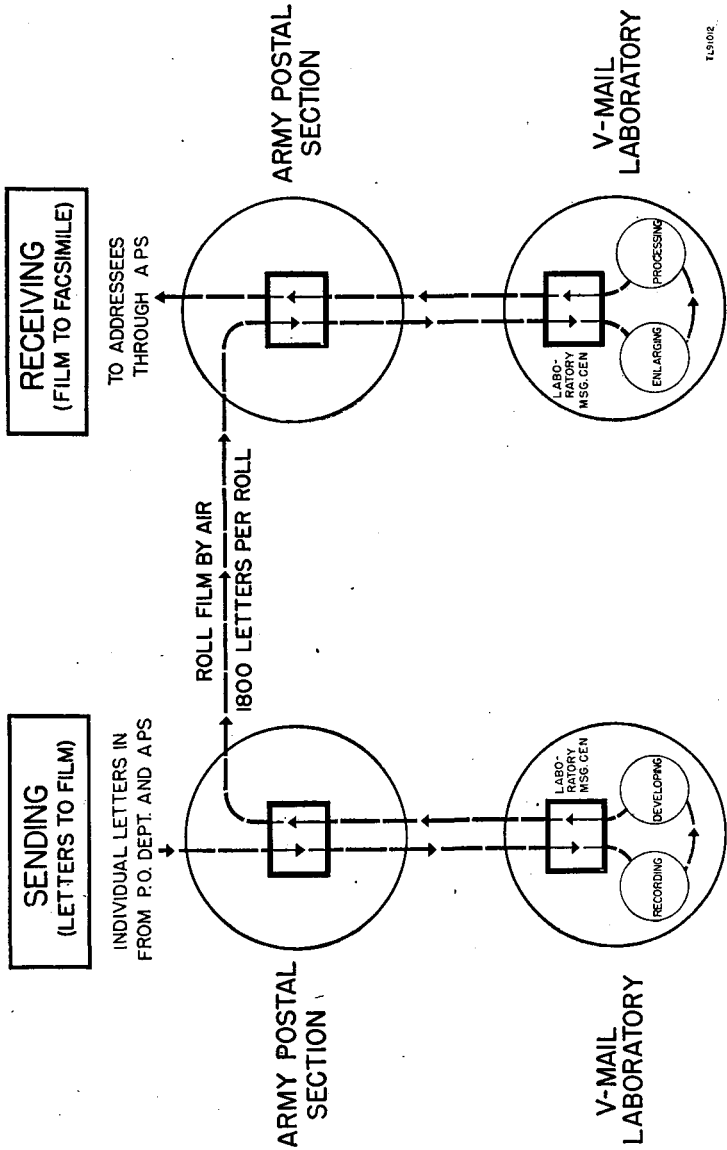

143002

Figure 1. General V-mail flow chart.

Post Office. Assignments of detachments will be only to base post offices preparing photomail for processing and dispatch. The organization of a type detachment is shown in figure 2. The basis of assignment for the various teams is given in the remarks column of part II, section I, T/O & E 12-601.

a. **DETACHMENT HEADQUARTERS.** A detachment headquarters will be authorized on the basis of total personnel in the detachment. Detachments with personnel numbering less than 40 will secure administration from the base post office. The personnel of a detachment headquarters may be combined with the headquarter-

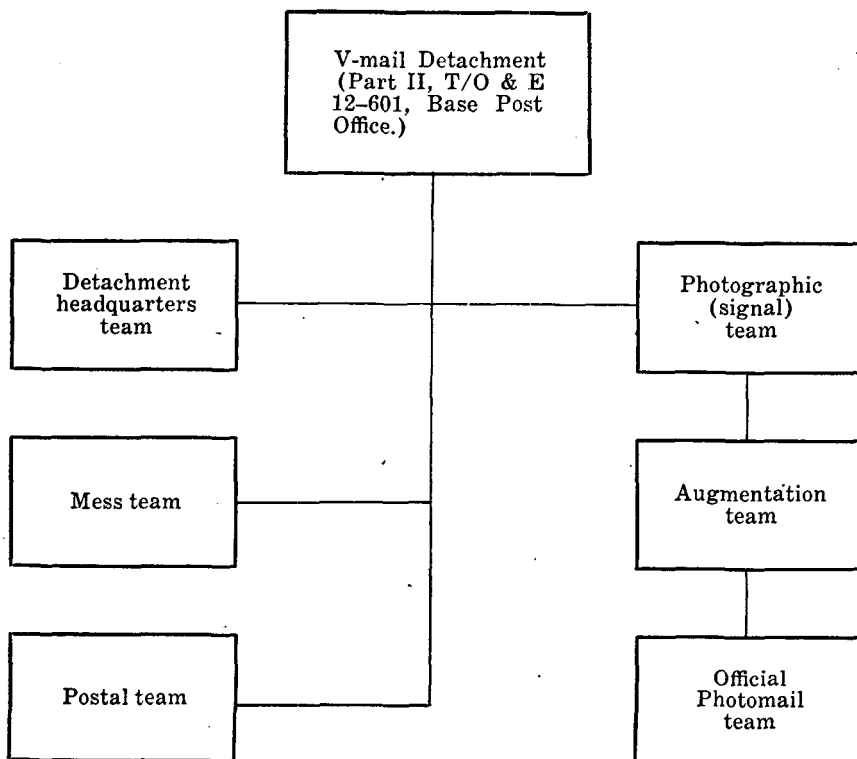

Figure 2. Type V-mail detachment.

Note. A detachment headquarters or mess team will not be included in a detachment when total personnel in a detachment is less than 40.

ters section of the base post office to which attached. The types authorized assist in the preparation of V-mail records and perform administration.

b. **MESS TEAMS.** Detachments with personnel numbering less than 50 will secure mess from the base post office. Mess teams of type authorized may be combined with the mess of the base post office.

c. **POSTAL TEAMS.** The postal teams will be authorized in accordance with the volume of mail to be handled.

d. **PHOTOGRAPHIC (SIGNAL) TEAMS.** These are photomail teams in T/O & E 12-601, and are authorized in accordance with the volume of mail to be handled.

e. **AUGMENTATION TEAMS.** Augmentation teams may be used to augment the postal and photographic teams of section II, T/O & E 12-601.

f. **OFFICIAL PHOTOMAIL SECTION.** The type FA official photomail section is complete within itself and provides facilities for handling of official photomail by photographic means. Official

photomail will be processed separately from V-mail. When volume requires, basic team combinations of postal and Signal Corps teams may be utilized to process official photomail in place of team type FA.

Section II. PHOTOMAIL TECHNICAL OPERATION

15. Photomail Installations

A photomail installation should be established in the most suitable position for sending and receiving operations. The installation should be designed to secure the maximum output of photomail with the least amount of delay and waste, and at the same time provide a means for a steady flow of work. The fundamental requirements for establishing photomail installations are discussed in paragraphs 16 to 22, inclusive.

16. Location Requirements

The proper location of a photomail laboratory is vital to the efficient operation of the photomail service. Transportation facilities and an adequate source of water and power are among the primary requirements governing the location of a photomail laboratory.

17. Transportation

The V-mail laboratory should be located adjacent to or near the air transport facilities normally handling air mail for the base post office concerned.

18. Water

The laboratory requires an adequate source of water under pressure. Any water satisfactory for human consumption may be presumed to be satisfactory for photographic purposes, although additional and frequent filtering may be necessary. It is preferable to maintain V-mail laboratories only when adequate water is available rather than to undertake the correction of a deficiency. Laboratories can operate successfully on most clear water. Oily water is relatively satisfactory after filtering. Water with sufficient chemical taint to prevent ready use should be avoided. Certain types of contamination may not affect the quality of photographic solutions, but will decrease their life.

19. Electricity

Whenever possible, V-mail laboratories should be located adjacent to an adequate power source. Any appreciable voltage fluctuation will cause faulty recording of photomail. Foresight must be exer-

cised in estimating power requirements. When independent power equipment is employed, sufficient surplus capacity must be made available and the equipment operated at the exact cycles for which it is designed if voltage fluctuation is to be minimized.

20. Laboratory Buildings

Efficient operation is dependent upon laboratory buildings which furnish ample room for photomail equipment and operating personnel. Types of electric circuits and fixtures used in laboratory buildings in connection with film processing are described in AR 850-65.

a. **DARKROOMS.** Darkrooms may be improvised or constructed in any type of building or cellar whose floor or foundation will sustain the processing equipment, and which is capable of being made lightproof. Whatever the photomail accommodations, every effort should be made to create a housed, weather-protected installation because wind, dirt, and dust impede photographic processing. It may be necessary to set up prefabricated buildings when other suitable accommodations are not available in the vicinity of operations. If prefabricated buildings are used, a floor plan of equipment should be designed for the most efficient arrangement of equipment and processing rooms in the space available. All darkrooms are best located in a single block, the center of which is occupied by the finishing section. Darkrooms should be designed so that material in process may be passed through light trap openings rather than carried through passageways equipped with curtains which delay or hamper the ready passage of work.

b. **VENTILATION.** Adequate ventilation of processing rooms in photomail laboratories is necessary for the maintenance of photographic quality. It is also vital to the health of the darkroom operators. When it is necessary to use poorly ventilated space, personnel should be provided with reliefs and observe a schedule which permits rest periods and access to fresh air. Care must be taken in building light traps to provide a sufficient free passage of fresh air.

c. **CHEMICAL MIXING.** Chemical solutions should be prepared in a well-ventilated room unrelated to the storage or processing of sensitized materials. A weighing table equipped with an adequate scale should adjoin a sink with generous dimensions. The mixing tanks should adjoin the sink opposite to the weighing table and be in the most advantageous position for transfer of solutions to the replenishing tanks. A series of formula cards should be maintained in card index form, and the formulas (while conforming to the proportions furnished) should be computed in the largest amount of solution consistent with the needs of the laboratory in order to minimize human error in weighing. The use of special

or nonstandard solutions creates confusion and lack of confidence and responsibility in the laboratory and does not contribute to quality work. The feasibility of the use of standard formulas in varying strengths for all standard processing of sensitized materials has been well established.

d. MESSAGE CENTER. The message center should be well lighted and centrally located within the photomail laboratory.

21. Laboratory Signs and Waste

a. LABORATORY SIGNS. AR 850-65 covers the marking of exits and exit sign specification.

b. WASTE. Film discards and scraps constitute a fire hazard as determined by AR 850-65. Strict adherence to smoking regulations and the designation of closed waste receptacles for film discards will reduce fire hazards. All photomail film and paper discards must be handled in accordance with AR 380-5.

22. Allocation of Personnel

Personnel assignments should result in proper distribution of the functions of the sections among the personnel, both with regard to individual special qualifications and relative numerical requirements, based on the number of personnel assigned or available to the photomail laboratory. Maximum teamwork can be obtained only when each subdivision has assigned to it men with special aptitudes to handle the amount of work required of that section, and when that section is provided with an even flow of work involving all the phases of photography for which it is designed and equipped.

CHAPTER 3

TRAINING

Section I. GENERAL

23. Introduction

The following training material is written for information and guidance in training photomail personnel. This manual presents general training information but does not affect established training policies or procedures.

24. Objective

The training objective of signal photomail teams is to produce an organized, integrated, technical unit capable of performing its primary mission in extended field operations. A course of instruction on a particular type of equipment described in an appropriate technical manual should result in proficiency in the operation and maintenance of the equipment.

25. Training References and Guides

To obtain the latest training references and guides, it is necessary to consult recent editions of FM 21-6, List of Publications for Training; FM 21-7, List of War Department Films, Film Strips, and Recognition Film Slides; and FM 21-8, Military Training Aids. Instructional material will normally be taken from War Department manuals as modified by other War Department publications and local instructions. Training will be conducted in accordance with FM 21-5, Military Training; TM 21-250, Army Instruction; TF 7-295, Military Training; and TM 11-450, Training of Signal Communication Personnel, and the series of photomail technical manuals listed in paragraph 11.

26. Training Aids and Facilities

a. Training schedules and lesson plans should be adaptable to the scope of training prescribed. Appropriate training schedules will be posted where they may be observed by all trainees concerned. Details as to training aids, facilities, and equipment will be included so far as it is necessary to conduct efficient training without loss of time.

b. Every effort will be made to procure adequate training aids, equipment, and facilities necessary to carry out the prescribed program. When training aids and facilities are inadequate, schedules will provide for rotation of personnel.

Section II. SPECIALIST TRAINING

27. General

Trainees with previous photographic experience are normally chosen for training in photomail operation. Those who are chosen pursue a course in the basic fundamentals of photomail operation. These fundamentals familiarize each photomail trainee with the operation performed by each type of equipment in accomplishing the photomail mission. However, when trainees having previous photographic experience are not available, adequate training should be given in the fundamentals of photography prior to the specialist training period. This basic training is outlined in paragraph 34.

28. Individual Technical Training

Specialist training in the individual technical training period should be performed so that trainees will obtain individual experience which will prove valuable during actual operations. Individual technical efficiency should be developed to a high degree. The training of the individual must be balanced and emphasis must be placed on a few related types of operations which the trainee may be expected to perform. Instructors should endeavor to develop individual proficiency and technique, and encourage practice which improves photographic quality.

29. Standard Methods

Laboratory processes and methods should be standardized during specialist training to economize on time and material, aid in maintaining and improving quality of workmanship, and prevent confusion. Laboratory rules and regulations should be posted concerning cleanliness, orderliness, section or room arrangement, use of water and lights, breakage and replacement, labeling of sensitized material, handling of chemical solutions and partly used rolls of microfilm and paper, and general care of equipment.

30. Care of Equipment

Care of photographic equipment should be stressed throughout training. The production of satisfactory work by a photomail unit is dependent to a large extent on the working conditions of equipment. Frequent tests and inspections are made of equipment by the

unit commander during training phases. Definite inspection periods should be set up for the purpose of maintaining operating efficiency and particularly to ascertain whether instructions issued regarding operation of equipment are being observed by the trainees. Prompt and appropriate disciplinary action should be taken in case of neglect or abuse of equipment or disregard of orders or instructions concerning it.

31. Conservation of Photographic Material

Conservation of film and other photographic material should be emphasized at all times during training to prevent rapid exhaustion of photomail material in the theater of operations.

32. Project Work Forms

Project work forms should be introduced in the specialist training phase. These forms greatly facilitate the handling and processing of microfilm and paper. Proper accomplishment will increase production and work efficiency, and will aid in a proper and methodical arrangement for the accommodation of rolls of letters, bundles of facsimiles, and microfilm from the time of arrival to final disposition. These forms are discussed in section III, chapter 4.

33. Photomail Technicians

The specialist training program will serve to develop the following types of technicians in the signal photomail unit.

a. LABORATORY TECHNICIAN, V-MAIL OR MICROFILM (SSN:016). This type of technician will be required to operate microfilm equipment or supervise the work of a V-mail or microfilm processing laboratory in which negatives are developed and paper prints are made by continuous or still projection.

b. MICROFILM EQUIPMENT REPAIRMAN (SSN:158). This type of specialist will be required to repair, rebuild, adjust, and maintain in service the mechanical and electrical parts of microfilm photographic equipment and accessories.

34. Basic Technical Training

Basic technical training for specialists discussed in the preceding paragraph should be conducted in accordance with paragraph 18i, MTP 11-1, Mobilization Training Program for Signal Corps Enlisted Personnel of the Army Service Forces, 1 Jun 44. TM 1-219, Basic Photography, supplemented by technical manuals related to the equipment, will comprise the greater part of text material. The course as outlined in the MTP will include technical training in all types of photomail equipment and procedures. Proficiency charts as recommended by training publications will be main-

tained by instructors. During the first 4 weeks of basic technical instruction, training is centered on the practical use of various cameras, processing equipment, and technique. Critiques will be held on photographic quality. Subjects to be taught in basic technical training are discussed in paragraphs 35 through 45 which follow.

35. Basic Photography

The operations involved in photomail consist in a large part of processing photographic material and handling chemical solutions. The securing of maximum quality in photomail work requires that the trainee have a thorough understanding of film emulsion speed, contrast, latitude of film, and other fundamentals of photography. These fundamentals must apply as much as possible to photomail laboratory procedure, that is, film and paper processing. Discussion, demonstration, and practical exercises in the following points should be emphasized:

- a. Principles of the camera, lens apertures, light tight boxes, and film holders.
- b. Negatives, prints, development, washing, drying, and differences in developers.
- c. Use of washing and drying devices.
- d. Common troubles, causes, and remedies of overexposure, underexposure, reticulation, improper temperature of developer, and overdevelopment, and underdevelopment.
- e. Need for formulas for tropical developers and hardeners.
- f. Practical exercises in enlarging, developing, short stop, fixing, washing and drying.
- g. Necessity for cleanliness and washing equipment free from harmful chemicals.

36. Continuous Film Processing

a. GENERAL. Large quantities of microfilm are handled in the photomail laboratory. To facilitate processing, a continuous film processing machine is used. (See fig. 3.) The object of instruction in training should be the care and operation of equipment. Extreme care should be exercised at all times when operating continuous processing equipment. A break in any part of the unit will cause avoidable delay and unnecessary spoilage of film.

b. PRACTICAL EXERCISES. Practical exercises should be performed as follows:

- (1) *Film splicing.* Each trainee should be equipped with a hand splicer and several feet of old film. Allow each trainee to practice making splices in both the light and the dark. The instructor should check the splice and stress the importance of good splices.

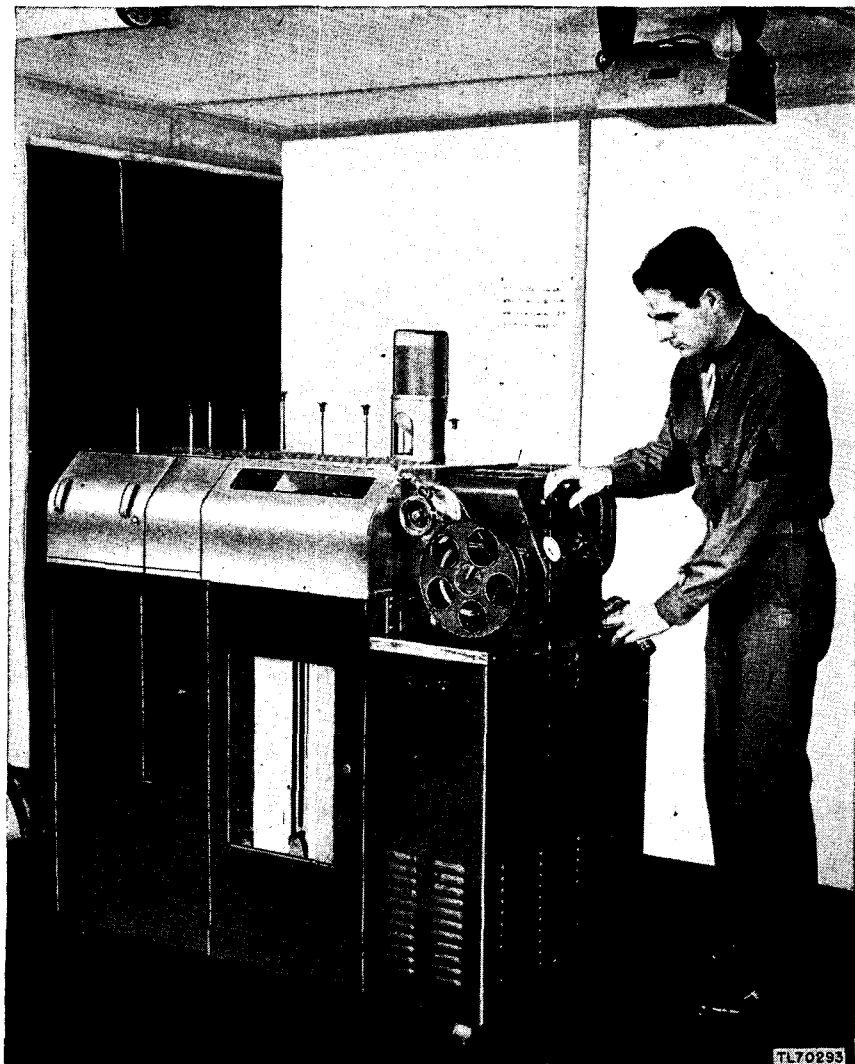

Figure 3. Continuous processing machine in operation.

(2) *Film loading.* Each trainee will practice loading a supply reel and splicing a new supply of film to the unit. Old film will be used for this purpose.

(3) *Operation.* Trainees will operate the unit in white light using leader in place of film. Each trainee will load a film supply reel, splice the supply reel of film and watch the unit while it is running. Processed film will be removed from the take-off. The instructor will make certain that each trainee is able to perform every operation correctly to insure successful operation of the machine. The trainees should be rotated to insure proper training. The instructor may permit the student to operate the machine

without assistance when he feels that the student is proficient.

37. Model C-1 Recorder Operation

a. GENERAL. The Model C-1 recorder is used to facilitate rapid photographic copying of correspondence on microfilm. (See fig. 4.) Discussion, demonstration, and practical exercises should be performed in training.

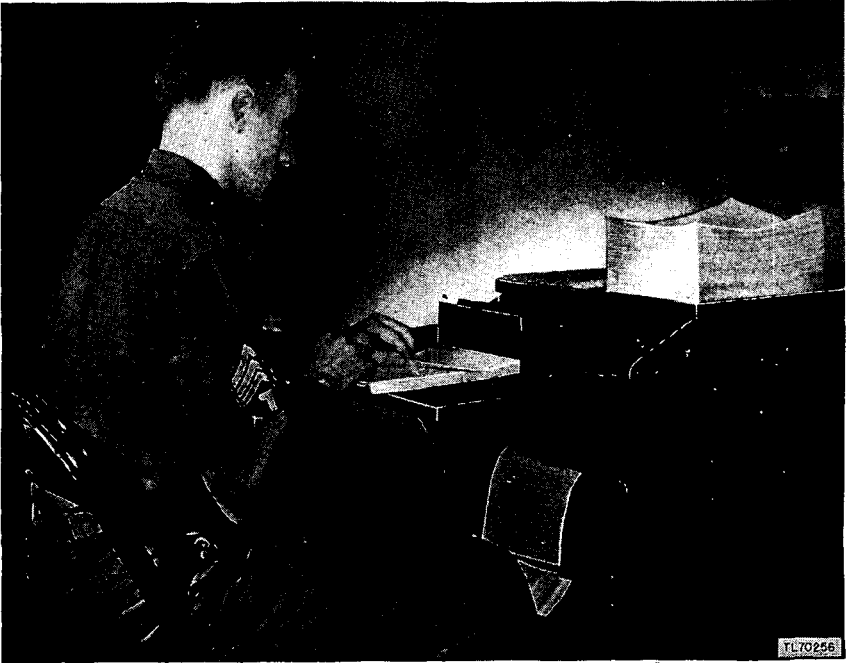

Figure 4. Continuous recorder operation.

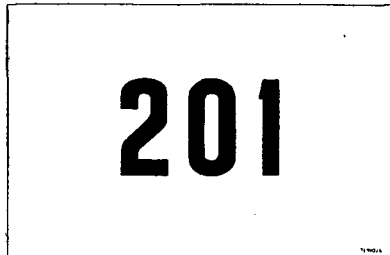

Figure 5. Overlapping portion of a veeder count target.

b. PRACTICAL EXERCISE. Each trainee should prepare the recorder for operation and will record 100 documents using a start target, work target, end target, and a veeder count target (fig. 5) every 20 documents. All necessary data will be entered on work

sheets and the shipping carton labeled accordingly. Mistakes in operation will be corrected immediately.

38. Film and Paper Inspection

Every photomail print represents an important message to an addressee. Care must be exercised to prevent sending defective microfilm or paper prints to addressees. The object of the microfilm and paper inspection course is to teach the trainee how to perform inspections, find defective microfilm (fig. 6) and prints, identify them, and take necessary steps to have prints reprocessed. Every effort is made to enable the trainee to acquire a skill in this field as quickly as possible. Emphasis is placed on discussion, demonstration, or practical exercises. (See TM 11-2301, 11-2302, and 11-2309.)



Figure 6. Film inspection.

During the course the following points are emphasized:

- a. Importance of all types of inspections.
- b. Contrasting receiving and sending operations and showing how receiving inspections are included in charting.
- c. Inspections of faulty rolls and group performance of inspecting faulty rolls.
- d. Threading a reader and splicing.
- e. Negative faults (fig. 7) and illustration of negative faults on film.

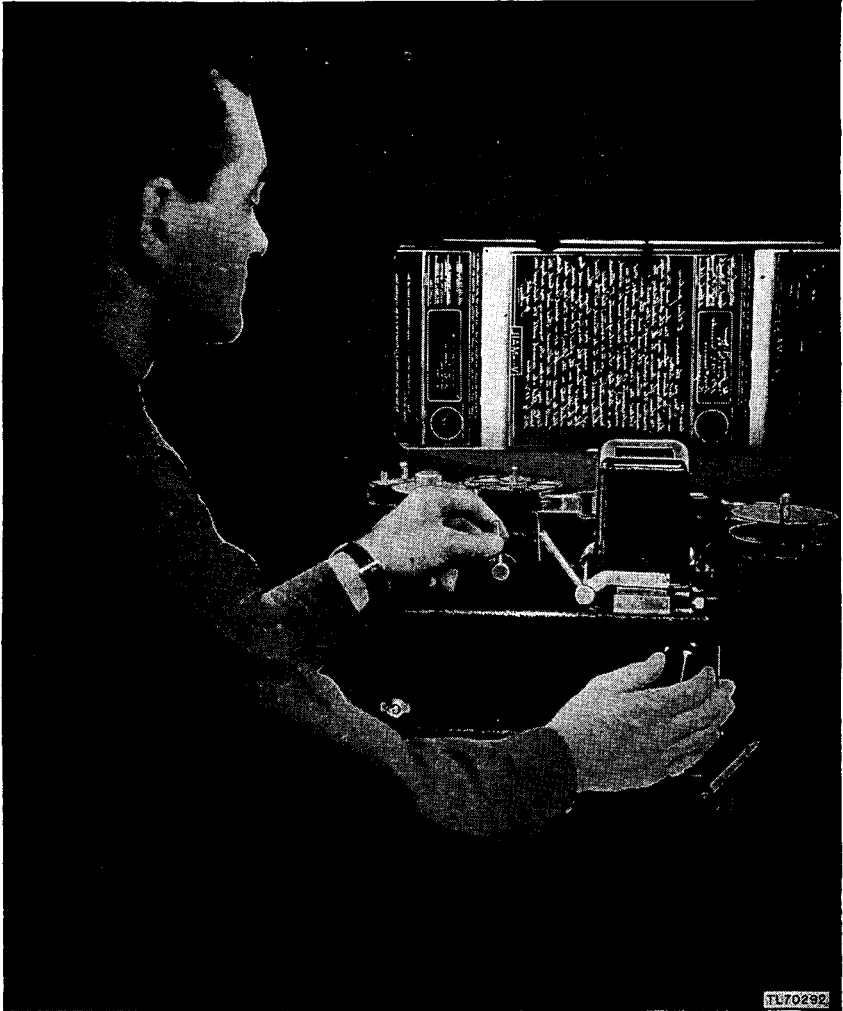

Figure 7. Locating negative faults on an inspection projector.

- f. Entries made on the retake form and the sending work sheet.
- g. Need for density tolerances.

- h. Densitometer as a measuring device of negative blackness, and reading the densitometer.
- i. Sending inspection, densitometer reading, and accuracy of sending work sheets and retake forms.
- j. Receiving charting procedure and inspection of the first wind.
- k. Foot candle readings and varying of printing time for different negative densities.
- l. Rough first inspections and faults.
- m. Winding film correctly on the reel.
- n. Finding low average meter reading and recording on the work sheet.
- o. Systems for recording different readings along the entire roll.
- p. Legibility as a primary consideration and marking black and white prints not within tolerances.
- q. Originating retake requests in the reprint department.
- r. Paper winding, inspecting (fig. 8), and making entries on the receiving work sheet and the reprint form.

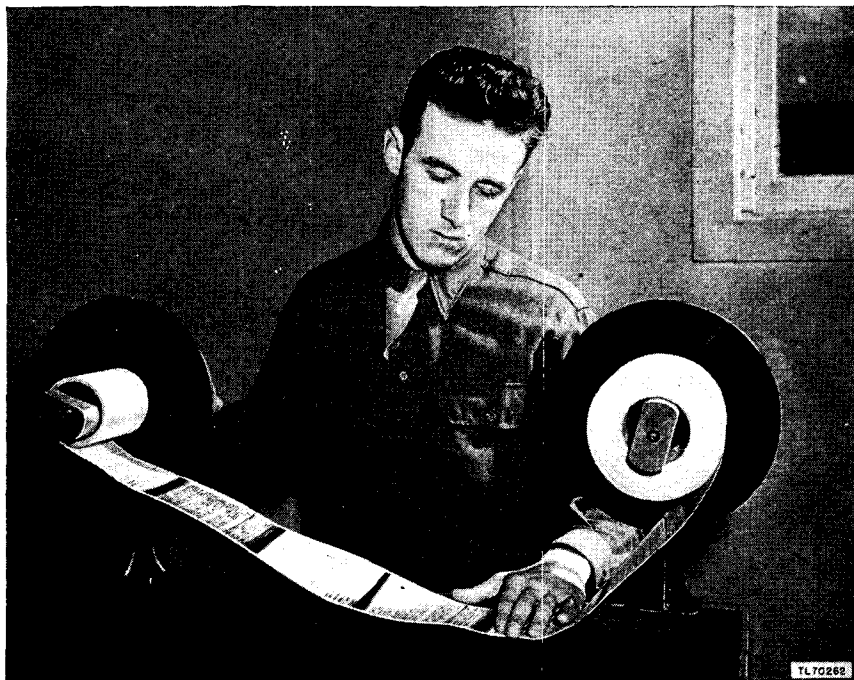

Figure 8. Inspecting paper.

- s. Choppers work entry sheet, duties of a chopper, and chopping technique. (See fig. 9.)



Figure 9. Chopping paper.

t. Discarding or reducing prints according to the inspector's marks.

39. Microfile Operation

a. Official military maps, charts, and blueprints are often received in an official photomail laboratory. These and other material cannot be photographed on a recorder. The object of microfile instruction is to teach the trainee how to operate and maintain the microfile camera. Emphasis is placed on mechanical performance rather than on photographic theory. Actual practice in the use of the equipment by the trainee is required.

b. PRACTICAL EXERCISE. In practical exercises, organize trainees in small teams and photograph copy for speed.

40. Enlarging

The object of the photomail enlarging specialist course is to teach trainees the use of the model A and model 10 enlargers in making official photomail prints. (See fig. 11.) Discussion, demonstration, and practical exercises are performed with emphasis placed on cooperation. (See TM 11-2300.)

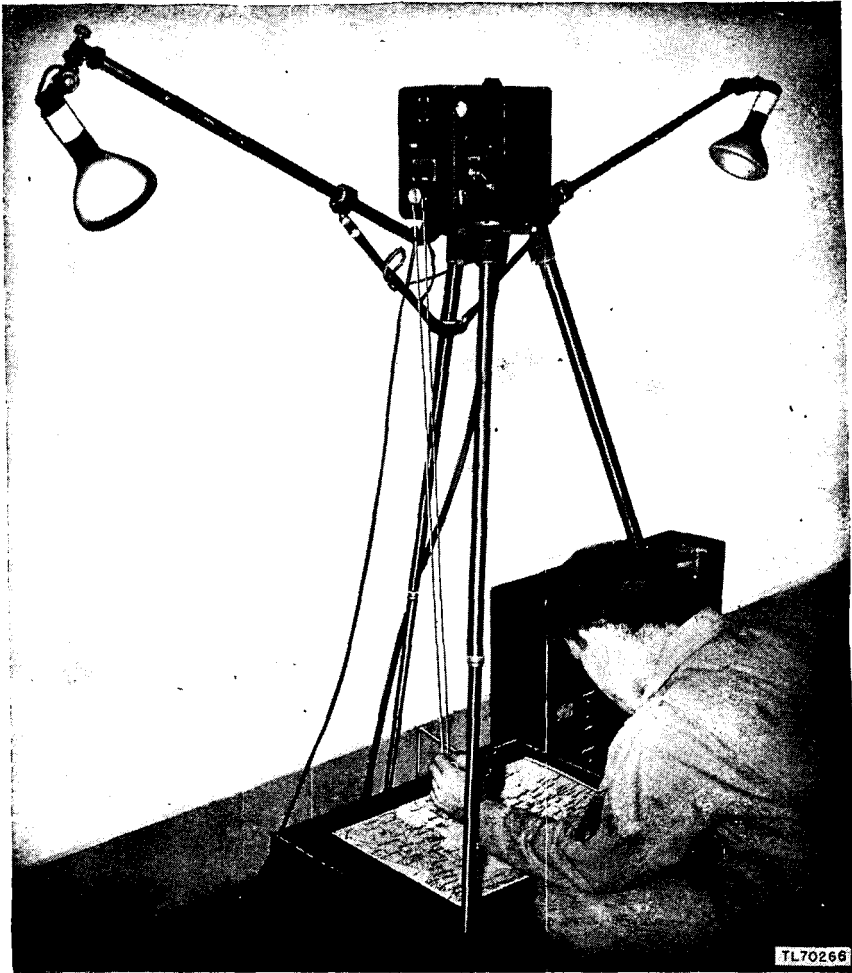

Figure 10. Recording a map on the microfile camera.

41. Paper Processing

a. GENERAL. The continuous paper processing machine is used in the automatic processing of large quantities of photomail prints. (See fig. 12.) Constant supervision must be exercised over the operating machine to prevent unnecessary stoppage or break-downs. Demonstrations, discussion, or practical operation of the equipment should be performed.

b. PRACTICAL EXERCISE. Practical exercise should be performed in the following sequence:

- (1) Thread and strip the machine.
- (2) Make various splices.
- (3) Make splices with the machine running.
- (4) Adjust wash temperature, demonstrate starting proce-

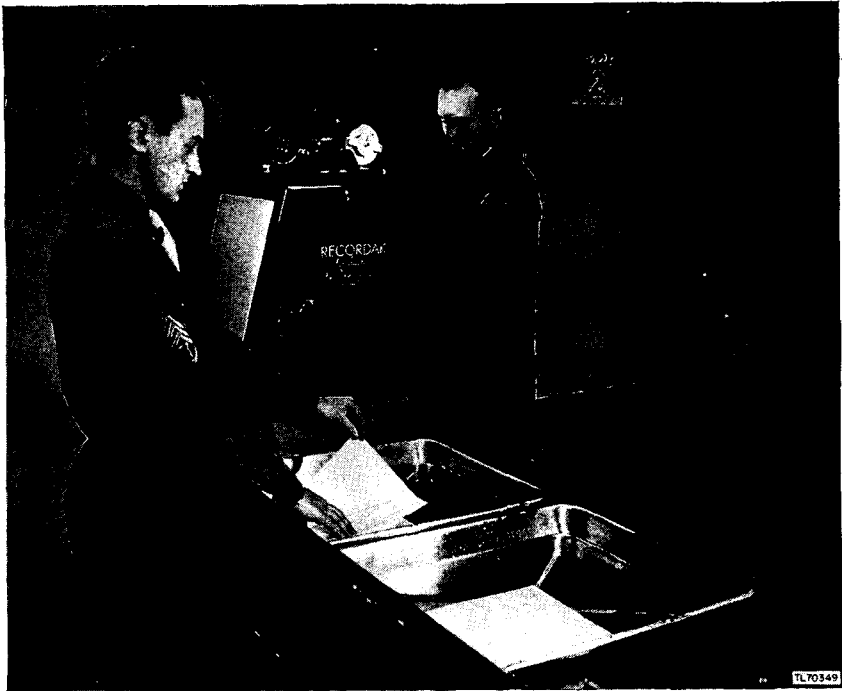

Figure 11. Printing official photomail correspondence.

cedure, adjust drying drum temperature, and practice using safelights.

(5) Practice the routine of shutting down the machine, turning off replenisher flow, and procedure of removing and cleaning racks, cleaning of the machine, and cleaning drying drum.

(6) Practice the procedure for handling breaks and slack in the machine.

42. Reel and Tank Film Processing

Film processing is one of the most important steps of photomail procedure. Without good negatives, clear reproductions are difficult to obtain. The object of film processing instruction is to teach the trainee the proper operation of developing equipment and processing procedure which includes preparation of chemicals, reel loading procedure (fig. 13), and the development of film and cleaning of equipment. Discussion, demonstration, and practical exercises should be performed. (See TM 11-2305.)

43. Continuous Enlarger

a. GENERAL. The continuous enlarger is used to print large quantities of photomail facsimiles. The object of training is to instruct the trainee in the operation of the continuous enlarger

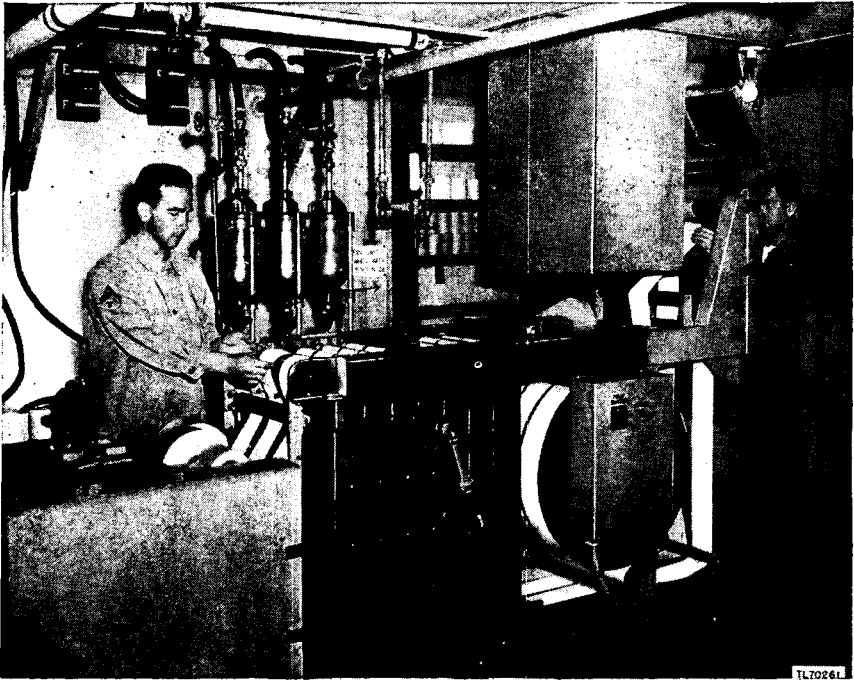

Figure 12. Threading a continuous paper processor.

with emphasis placed on exposure control. Demonstration, discussion, and practical operation should be performed.

b. PRACTICAL EXERCISE. (1) Each trainee will thread the enlarger with film and paper, adjust the F value, and set the voltage control.

(2) The instructor will explain causes of slippage, improper masking, fog, incorrect film winding, paper upside down, and improper identification of rolls of exposed paper.

(3) Under supervision of the instructor each trainee will expose 36 feet of paper and will practice wedging and masking.

44. Model N Enlarger

a. GENERAL. This machine is used as a hand operated machine for making V-mail reprints. These reprints result from the rejection of V-mail facsimiles during the inspection process.

b. PRACTICAL EXERCISE. Each trainee will have a practical exercise in threading film and paper into the enlarger and will print a minimum of six prints. Later the enlarger will be operated simulating field conditions.

45. Message Center Procedure

a. GENERAL. The many processes in the production of photo-



Figure 13. Loading film on reel for developing.

mail require a central agency to associate them and coordinate their operation. This agency is message center. In order to instruct the trainee in how to operate a message center efficiently, a short background of photomail and its official place in Army organization is explained to acquaint the trainee with the importance of his work. The trainee should be impressed with the inviolability of soldiers' mail and official photomail. All trainees will be impressed with the necessity for handling official documents in the interest of security and the safeguarding of classified material. The trainee should be shown the connection between the Signal Corps and the Army Postal Service. An entire message center should be set up in the classroom and the following points emphasized:

- (1) Problems of a message center, both receiving and sending.
- (2) Brief inspections, initiating receiving work sheets, checking correctness of numbers of film rolls on corresponding targets and boxes, flow sheets, and signing of receipts. (See fig. 16.)
- (3) Reasons for entries on the receiving work sheet.
- (4) Need for speed and rapid delivery of the film to the charting department.
- (5) Methods of releasing prints to the Army postal section by appropriate entries in the receiving log.
- (6) Need for retake system, and organization of retake forms in the reprint department.

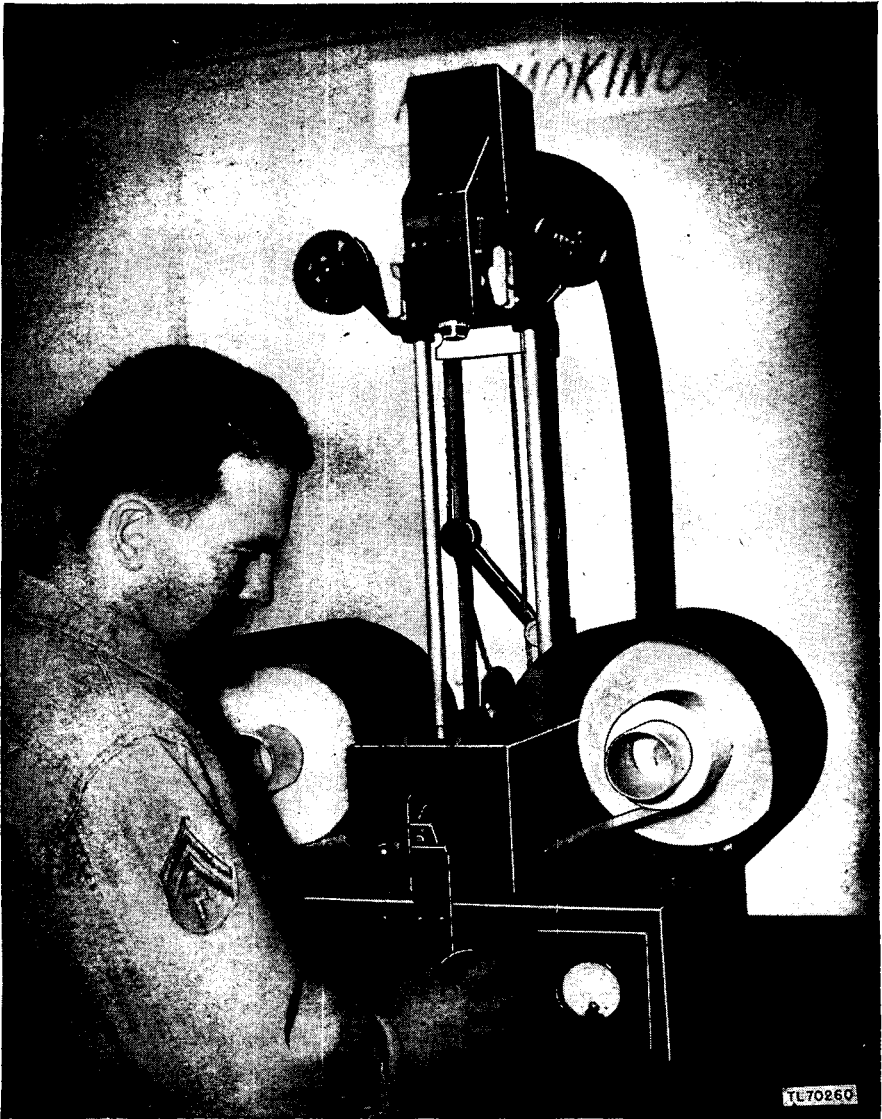

Figure 14. Setting voltage on a continuous enlarger.

- (7) Importance of not initiating duplicate requests for retakes.
- (8) Message centers disposition of packets of reprints.

b. PRACTICAL EXERCISES. Set up a dummy message center simulating operation under field conditions. Organize two V-mail stations; one acting as a sending station, and the other acting as a receiving station. Hold group performance tests in all phases of paper winding, inspecting, making proper entries in all forms, and chopping technique.



Figure 15. Enlarging and processing V-mail facsimile reprints.

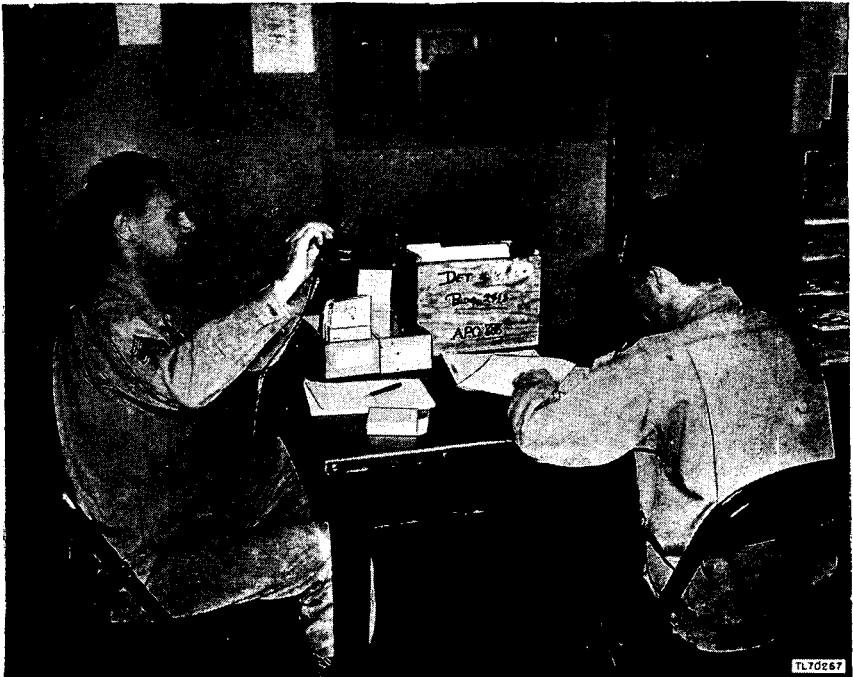

Figure 16. Message center clerk checking an incoming microfilm roll.

Section III. TEAM TRAINING

46. General

The team training phase in photomail normally extends over a period of 4 weeks. The object of training is to instruct the trainees in the operation of a complete photomail station and to illustrate the necessity for interdepartmental efficiency. The ultimate goal of team training is the coordination of the operation of each piece of photomail equipment with individual effort to achieve a smoothly operating unit.

47. Segregating Trainees

Trainees who have completed the specialist phase of training are screened in accordance with their ability, aptitude, instructor's rating, and preference as to type of work. The entire roster of specialist trainees will be divided into three groups. Each group will consist of a small number of trainees with a key trainee acting as an assistant to the instructor in charge. During the first 2 weeks of team training, the men are assigned to one of the following three groups and are rotated only within that group.

a. GROUP I, PAPER PROCESSING.

- (1) Continuous enlarger.
- (2) Charting.
- (3) Continuous paper processing.
- (4) Reprints and reduction.
- (5) Chemical mix.
- (6) Chief darkroom operator.

b. GROUP II, FILM PROCESSING.

- (1) Film processing (reel).
- (2) Film processing (continuous processor).
- (3) Film inspection.
- (4) Microfilm equipment repairman.
- (5) Chief darkroom operator.

c. GROUP III, CLERICAL.

- (1) Message center.
- (2) Recorder.
- (3) Paper inspection.
- (4) Paper chopping.
- (5) Microfile.

48. Choosing Chief Processors

Two chief darkroom operators, chosen by instructors on the basis of classroom work, leadership, and ability should be assigned to assist the instructors in charge of groups I and II. The chief darkroom operator will assist in the general supervision of photomail

laboratory production and personnel, and enforce routing procedure and systems prescribed. He should learn to anticipate supply and personnel requirements and how to facilitate teamwork and undelayed production. He should be capable of keeping microfilm and printing up to and better than standard quality and determining corrective measures for substandard work. The development of chief processors will be vigorously pursued during the team and combined training phases.

49. Rotation of Personnel

In the paper processing group and the clerical groups, the trainees will normally be rotated daily in the various jobs of each group. In the film processing group, two men will be assigned to the continuous film processing machine for the entire first 2 weeks; the remaining men will be rotated daily. Each group will have an opportunity to operate each department of the photomail station.

50. Final Team Training

After the first 2 weeks of team training have been completed, the trainees will be placed in the job for which they are best suited, as shown by the team training cycle just completed. The number of men assigned to each group should remain the same for the final team training cycle and during this cycle there should be no rotation of jobs. The trainees assigned to the continuous film processing machine and the chief darkroom operators will continue in their jobs for the entire 4 weeks of team training if their work has been satisfactory. For the final 2 weeks of training, one instructor will assume the position of chief processor and the remaining two instructors will act as assistant chief processors. The duties of each man in a particular job are listed in paragraphs 51 through 67 which follow.

51. Chief Processor

The chief processor will be responsible for :

- a. The operation of the entire station.
- b. The condition of the equipment and the laboratories as a whole.

52. Assistant Chief Processor

- a. THE ASSISTANT CHIEF PROCESSOR (SENDING) :
 - (1) Assists the chief processor in his duties.
 - (2) Is directly responsible for all those operations directly concerned with the sending function.
- b. THE ASSISTANT CHIEF PROCESSOR (RECEIVING) :
 - (1) Assists the chief processor in his duties.

(2) Is directly responsible for all those operations directly concerned with the receiving function.

53. Chief Darkroom Operator

a. THE CHIEF DARKROOM OPERATOR (SENDING) :

- (1) Assists the assistant chief processor (sending).
- (2) Is directly responsible for maintaining constant flow of work in the sending operation.

b. THE CHIEF DARKROOM OPERATOR (RECEIVING) :

- (1) Assists the assistant chief processor (receiving).
- (2) Is responsible for maintaining a constant flow of work in the receiving operation.

54. Continuous Enlarger Operator

a. CLASS A. The duties of the class A operator will include.

- (1) Those of the class B operator, and the responsibility for all work on the continuous enlarger.
- (2) Supervising the work of the class B operator.
- (3) Keeping a constant check on equipment and notifying the chief processor in case of trouble.

b. CLASS B. The duties of the class B operator will be to :

- (1) Obtain film from the enlarger "in" box.
- (2) Load paper and film and run Hurter and Driffield (H & D) density strips.
- (3) Adjust the enlarger from data on the work sheet.
- (4) Check the enlarger while in operation, being constantly on the alert for trouble.
- (5) Identify each roll of paper at the beginning and the end.
- (6) Remove paper and film.
- (7) Fill out proper blanks and work sheets.
- (8) Send exposed paper to the paper processing room.
- (9) Place film in the continuous enlarger "out" box.

55. Charter Operator

a. CLASS A. The duties of the class A operator include:

- (1) Those of the class B operator and the responsibility for all film charted in the station.
- (2) Supervising the work of the class B operator.
- (3) Checking the equipment constantly and notifying the chief processor in case of trouble.

b. CLASS B. The duties of the class B operator include:

- (1) Obtaining film from the charting "in" box.
- (2) Checking film to make sure that it is wound on a light-weight reel correctly.
- (3) Charting film and entering lowest constant foot candle reading on work sheet.

- (4) Inspecting film briefly for general troubles such as dirt, fog, etc., and cleaning film with carbon tetrachloride.
- (5) Signing work sheet.
- (6) Placing charted film in charting "out" box.

56. Continuous Paper Processing Operator

a. CLASS A. The duties of the class A operator include:

- (1) Those of the class B, C, and D operators and the responsibility for all production on the paper processing machine.
- (2) Supervising the work of other operators.
- (3) Checking the equipment constantly and notifying the chief processor in the event of trouble.

b. CLASS B. The duties of the class B operator include:

- (1) Those of the C and D operator.
- (2) Checking the orifice flow and temperature of solutions.
- (3) Checking to see that the solution supply tanks are kept filled to the proper level.
- (4) Checking chemical quality from H & D strips.
- (5) Keeping a chart of work being performed on the machine, and work taken off the machine.
- (6) Supervising the work of the C and D operators under the guidance of the class A operators.

(7) Assisting in the start-up and shut-down of the machine and in the cleaning of it.

c. CLASS C. The duties of the class C operator include:

- (1) Obtaining paper from the light lock or pass box.
- (2) Splicing on rolls at the supply end of the machine.
- (3) Checking paper identity as it is put on the machine.
- (4) Watching the supply end of the machine for trouble.
- (5) Assisting in the start-up and shut-down of the machine and in the cleaning of it.

d. CLASS D. The duties of the class D operator include:

- (1) Watching the take-off end of the machine for trouble, and removing finished rolls, making sure they are correctly identified at each end.
- (2) Taking off H & D strips and writing the necessary information on the back.
- (3) Assisting in start-up and shut-down of the machine and in the cleaning of it.

57. Reprint and Reduction

a. CLASS A OPERATOR. The duties of the class A operator include:

- (1) Those of the class B, C, and D operators.
- (2) Obtaining film from reprint and reduction "in" box.
- (3) Supervising duties of other operators.

(4) Keeping a constant check on quality of reprints and reductions.

(5) Checking finished reprints against reprint sheet.

(6) Signing work sheets.

(7) Returning film and work sheet to reprint and reduction "out" box.

(8) Making final decision as to reprint or retake, and initiating "request for retake" sheet.

b. CLASS B OPERATOR. The duties of the class B operator include:

(1) Loading the Model N enlarger with film and paper.

(2) Locating negatives for reprints.

(3) Operating the Model N enlarger, checking constantly with the class C operator as to quality.

(4) Assisting in the clean-up of the reprint room.

c. CLASS C OPERATOR. The duties of the class C operator include:

(1) Developing and rinsing prints.

(2) Immersing reductions in the fix.

(3) Keeping check on number of prints processed in any batch of chemicals and changing chemicals at the proper time.

(4) Assisting in the clean-up of the reprint room.

d. CLASS D OPERATOR. The duties of the class D operator include:

(1) Fixing, washing, and drying reprints.

(2) Reducing, fixing, washing and drying dark prints.

(3) Assisting in the clean-up of the reprint room.

58. Chemical Mixer

The duties of the chemical mix man are as follows:

a. Mix all chemicals used in the laboratories.

b. Keeps an adequate supply of all chemicals on hand at all times.

c. Keeps a record of all chemicals mixed.

d. Is responsible for the condition of the chemical mix room.

59. Film Processor (Reel)

The duties of the film processor (reel) are as follows:

a. Obtains film to be processed from film processing "in" box.

b. Processes the film on the reel film machine using standard procedure.

c. Reads density of processed film and enters it on work sheet.

d. Makes proper entries on the work sheet.

e. Returns film properly packaged together with work sheet to the film processing "out" box.

60. Film Processor (Continuous)

a. CLASS A. The duties of the class A operator include:

(1) Those of the class B operator and the responsibility for all continuous film processing production in the station.

(2) Checking the machine, operating speed, solution temperature, and drying condition.

(3) Checking background density and H & D's on processed film.

(4) Assisting in start-up and shut-down of machine.

(5) Watching machine constantly for mechanical trouble and notifying the chief processor if any trouble occurs.

b. CLASS B. The duties of the class B operator include:

(1) Assisting in the start-up and shut-down of the machine.

(2) Loading work on the spools and splicing work on the machine.

(3) Watching the machine for any irregularities and maintaining correct replenishment rate for the developer.

(4) Changing stop bath and fixing bath at predetermined times.

(5) Taking work off the machine and placing it properly boxed in the film processing "out" box.

(6) Making proper entries on the work sheet.

61. Film Inspector

a. CLASS A. The duties of the film inspector class A include:

(1) Those of the class B operator and the responsibility for all film inspected in the station.

(2) Supervising the work of the class B operator.

(3) Acting as relief for the class B operator.

b. CLASS B. The duties of the film inspector class B include:

(1) Obtaining film from film inspection "in" box.

(2) Inspecting film and cleaning it if necessary.

(3) Punching out all unprintable negatives and initiating a retake sheet.

(4) Cleaning the machine each day.

(5) Signing work sheet and placing film properly boxed together with work sheet and retake sheet in film inspection "out" box.

62. Microfilm Equipment Repairman

The duties of the microfilm equipment repairman are as follows:

a. Responsibility for correct operation of all photomail equipment and performance of corrective maintenance only.

b. Preparation of preventive maintenance schedules and daily inspection of equipment.

c. Responsibility to the chief processor and officer in charge only.

63. Message Center Clerks

a. CLASS A. The duties of a class A message center clerk include:

- (1) Those of the class B clerks.
- (2) Supervising the work of class B and C clerks.
- (3) Responsibility for all records concerning the receiving and sending operations.

b. CLASS B (SENDING). The duties of the class B sending operator include:

- (1) Keeping records of the sending operation.
- (2) Preparing documents for photographing.
- (3) Initiating the sending work sheet.
- (4) Pulling documents for retakes.
- (5) Seeing that original letters are properly filed to await acknowledgment.

c. CLASS B (RECEIVING). The duties of the class B receiving operator include:

- (1) Keeping the records of the receiving operation.
- (2) Initiating the receiving work sheet.
- (3) Forwarding any "request" for retakes" initiated by the reprint department.

64. Recorder Operator

a. CLASS A. The duties of the class A recorder operator include:

- (1) Those of the class B operator and the responsibility for all the work in the recording department.
- (2) Supervising the work of the class B operator.
- (3) Acting as relief for the class B operator.

b. CLASS B. The duties of the class B recorder operator include:

- (1) Performing first echelon maintenance at the start of each day.
- (2) Obtaining work from message center.
- (3) Printing an H & D test on the start of each roll of film.
- (4) Loading camera for photographing.
- (5) Photographing documents, using correct target order.
- (6) Unloading camera after photographing and placing film and work sheet, properly boxed, in the recorder "out" box.

65. Paper Inspector

The duties of the class A paper inspector include:

- a. Assembling paper numerically as it comes from the continuous processing room.
- b. Inspecting paper, marking prints to be discarded, and initiating a reprint sheet.
- c. Marking prints for reduction.
- d. Passing inspected paper on to choppers with film.

66. Paper Chopper Operator

The duties of the paper chopper operator are as follows:

- a. Chops all prints to a uniform size.
- b. Discards prints that have been duplicated and marked as unsuitable by the paper inspector.
- c. Places prints for reduction in the proper box.
- d. Bundles all prints of a certain roll together and delivers them to the message center with corresponding roll of film.
- e. Makes proper entry on work sheet.

67. Microfile Operator

a. CLASS A. The duties of the class A microfile operator include:

- (1) Those of the B, C, and D operators and the responsibility for all microfile production.
- (2) Supervising the work of the B, C, and D operators.
- (3) Keeping a constant watch of the equipment used and reporting any irregularities of operation to the chief processor.

b. CLASS B. The duties of the class B microfile operator include:

- (1) Loading and unloading the camera.
- (2) Performing actual photographing.
- (3) Placing exposed film, properly boxed with its work sheet, in the microfile "out" box.

c. CLASS C. The duties of the class C microfile operator include:

- (1) Preparing documents for photographing.
- (2) Assisting the class B operator in photographing.

d. CLASS D. The duty of the class D microfile operator consists of assisting the class B operator in photographing.

68. Preparation for Final Team Training

In order to have a successful start in final team training, the laboratory should be completely set up and ready to operate. All equipment must be clean, in excellent working condition, and in its correct place for operation. The correct exposure setting for each recorder should be determined. The following equipment and

allied material should be carefully checked prior to beginning team training:

- a.* "In" and "out" boxes should be procured for each operation.
- b.* There should be enough chemicals mixed to enable the station to operate at full capacity until the chemical mix man can replenish them.
- c.* Message centers will be organized to receive rolls of letters and film from the Army postal section and exchange film between the laboratories.
- d.* Enough forms should be provided to accommodate 400 rolls of production.
- e.* Sufficient letters to make up at least 50 rolls of letters (500 per roll), should be available.
- f.* Code letters and an APO mailing address should be assigned to each station.
- g.* There will be 10 rolls of film, completely processed and inspected in the message center.
- h.* The above rolls will have been received in the receiving logbook and all records adjusted accordingly.
- i.* The rolls of film will contain the first 10 targets of another station and will suffice to start the receiving function operating almost immediately.
- j.* There will be 10 bundles of letters in the message center, each with a new target containing the code letters assigned.
- k.* These letters will have been received in the sending log book and all records adjusted accordingly.
- l.* There should be sufficient roll film, rubber bands, staples, ammonia, paper tape, string, prepared dry chemicals, etc., to insure proper operation.

69. Allocation of Personnel

Personnel duty assignments to definite rooms or sections within the laboratory build morale. A chart bearing the names of personnel and illustrating relationship of their work to that of the laboratory as a whole assists in creating teamwork, tends to maintain maximum training efficiency during periods of personnel exchange and substitution, reduces friction, and establishes responsibility.

70. Production Reports

At the end of each week of team training a production report must be submitted to the officer in charge of the training unit. The chief processor at the end of each shift will obtain from the sending and receiving logs a complete report as to work done during the shift. These figures will be totaled and submitted in the following form:

PRODUCTION REPORT WEEK OF 1 MAY 44 SHIFT A-14
SENDING

	<i>Received</i>	<i>Shipped</i>	<i>On hand</i>
2 May 44	23	18	5
3 May 44	18	8	15
4 May 44	17	18	4
5 May 44	6	16	4
Totals	<u>64</u>	<u>60</u>	<u>4</u>

Speed of handling (film)

Rolls in 12 hrs	48
Rolls 12 to 24 hrs	12
Rolls over 24 hrs	0
	<u>60</u>

Status of work on hand

Film to be inspected	3
Letters to be recorded	1
	<u>4</u>

RECEIVING

	<i>Received</i>	<i>Shipped</i>	<i>On hand</i>
2 May 44	4	1	3
3 May 44	20	7	16
4 May 44	14	25	5
5 May 44	16	15	6
Totals	<u>54</u>	<u>48</u>	<u>6</u>

Speed of handling (prints)

Rolls in 12 hrs	42
Rolls 12 to 24 hrs	6
Rolls over 24 hrs	0
	<u>48</u>

Status of work on hand

Paper exposed for processing	3
Film to be enlarged	3
	<u>6</u>

JOHN JONES
Chief Processor

CHAPTER 4

OPERATING PROCEDURE

Section I. ARMY POSTAL SECTION

71. General

a. ~~CODE DESIGNATIONS.~~ Photomail stations are assigned two-letter code designations by the Adjutant General's Office. These code designations are used to identify the station in reports and dispatch schemes. Each film roll is given a code group, which is comprised of the code letters of the station of origin, the number of the film roll, and the code letters of the station of destination. For example, in the code group: AB 47 FL, AB would be the code letters of the sending station, 47 the number of the film roll, and FL the code designation of the receiving station.

b. ~~NUMBERING PHOTOMAIL FILM ROLLS.~~ The numbering of the V-mail film rolls will be started quarterly with the number 1, each station of origin numbers film rolls consecutively for each station of destination until the first day of the succeeding quarter, when it again reverts to number 1. This number starts anew with the number 1 yearly in the case of official photomail.

72. Sorting

a. Original V-mail letters are received and distributed to the proper V-mail serving station. The sorted groups of original letters are opened and inspected.

b. Letters are divided into three groups representing their reproduction qualities. These groups are:

- (1) Typewritten and written in ink.
- (2) Pencil.

(3) Letters which contain inclosures, are damaged, or do not have complete addresses, or all questionable letters which indicate the final facsimile will not be legible.

73. Bundling

All letters in group 3 are resealed and forwarded as regular mail. The remaining lots of letters are tied into bundles containing 1,800 V-mail letters which can be recorded on a 100-foot reel of 16-mm film.

74. Roll Numbers

Each bundle of original letters is assigned a roll number in accordance with paragraph 71. This number also designates the corresponding roll of film containing the micronegatives for the bundle of letters.

75. Sending Records

a. An improvised flow sheet listing the rolls of letters and their roll numbers is accomplished. The rolls of letters, accompanied by the sending flow sheet, are forwarded to the associated Signal Corps V-mail laboratory for recording.

b. Flow sheets should be constructed so that a small section

Rolls (Bundles) Received From APO				(A PO) Sending Flow Sheet		
Roll Number	Number of Letters	Date	Time	Date Shipped	By Whom Shipped	Remarks
1						
2						
3						
4						
5						
6						
7						
8						
9						
10						
11						
12						
13						
14						
15						
16						
17						
18						
19						
20						

1.9033

Figure 17. Army post office sending flow sheet.

of the sheet can be separated by tearing it along a perforated line. (See fig. 17.) This small section contains a duplicate listing of assigned roll numbers and is received by the associated V-mail laboratory and returned to the APO V-mail section. The larger section of the sending flow sheet remains in the V-mail laboratory until all the letters have been satisfactorily microfilmed. This large section is then returned to the V-mail section with the proper information indicating dates of recording, shipping, and any extraordinary data together with the processed film and the original

DAILY V-MAIL STATION REPORT <small>COVERING PERIOD 0001 TO 2400</small>		TO: THE ADJUTANT GENERAL <small>WAR DEPARTMENT WASHINGTON 25, D.C. ATTENTION: ARMY POSTAL SERVICE</small>			<small>FROM</small> _____	<small>CONTROL APPROVAL SYMBOL XAO-150</small>	
<small>DATE</small> _____					<small>DATE</small> _____		
V-MAIL		DISPATCHED TO			RECEIVED FROM		
<small>NO.</small>	<small>STATION CODE</small>	<small>TOTAL ROLLS</small>	<small>TOTAL LETTERS</small>	<small>DISPATCH NUMBERS</small>	<small>STATION CODE</small>	<small>TOTAL ROLLS</small>	<small>TOTAL LETTERS</small>
1.							
2.							
3.							
4.							
5.							
6.							
7.							
8.							
9.							
10.							
11.							
12.							
13.							
14.							
15.							
16.							
17.							
18.							
19.							
20.							
21.	TOTALS						
MICRO-FILMING AND PROCESSING TIME		ROLLS DISPATCHED			ROLLS RECEIVED		
		<small>LESS THAN 24 HRS</small>	<small>24 TO 36 HOURS</small>	<small>OVER 36 HOURS</small>	<small>LESS THAN 24 HOURS</small>	<small>24 TO 36 HOURS</small>	<small>OVER 36 HOURS</small>
I CERTIFY THAT THIS IS A TRUE STATEMENT OF THE V-MAIL BUSINESS AT THIS STATION ON THE DATE SHOWN							
<small>REMARKS</small> _____					<small>SIGNATURE</small> _____		
					<small>DESIGNATION</small> _____		

W.D., A.G.O. FORM NO 950 THIS FORM SUPERSEDES W.D., A.G.O. FORMS NOS. 961 AND 962, 22 December 1949, WHICH WILL NOT BE USED AFTER RECEIPT OF THIS REVISION. 26-93556-304

Figure 18. Daily V-mail station report.

companies the rolls of film from the receiving V-mail section to the associated Signal Corps V-mail laboratory. A part of the flow sheet is receipted and the other part is returned to the V-mail section together with the enlarged prints.

77. Acknowledgment of Receipt

Upon receipt by the V-mail section of all completed facsimiles, the receiving V-mail section notifies the sending station that the film roll has been satisfactorily reproduced and that authorization is granted to destroy the corresponding original letters. This is accomplished by the use of WD AGO Form 949. (See fig. 20.) Instructions for use of the form are printed on the face thereof.

78. Folding, Inserting, Delivery

The final operation of the receiving V-mail section is the folding and inserting of the facsimile into window-type envelopes preparatory to delivery. The facsimiles are then forwarded and delivered to the addressees.

79. Retakes

Occasionally a request may be made by a receiving V-mail section for the sending V-mail section to rephotograph letters. This request is made on WD AGO Form 949 in conjunction with authorization to destroy original letters. It is the responsibility of the V-mail section receiving this request to see that the letters in question are extracted and added to a roll of letters going to the requesting section.

80. Retake Target

When retakes are added to a roll of original letters, they are placed at the end of the roll and preceded by the completed WD AGO Form 949 on which the retakes were requested. When retakes are withdrawn from a bundle, they lose all identity in connection with that bundle and are treated as original letters on a new roll.

81. Destruction of Letters

The original letters are destroyed only after receipt of a properly executed Form 949 from the receiving V-mail station. The original letters are destroyed by pulping or burning and their destruction is witnessed by a commissioned or noncommissioned officer.

82. Disposition of V-mail Microfilm

V-mail microfilm which has been reproduced is destroyed by burning in the presence of a commissioned or noncommissioned officer

various oversea stations. This service is available to other branches of the Government as well as the War Department and will be accorded any communications eligible for mailing under the penalty privilege.

a. CONTINENTAL UNITED STATES. Material originating within the continental United States will be forwarded by the originator to the War Department Foreign Mail Room, The Pentagon. All Official Photomail handled through the War Department Foreign Mail Room is microfilmed or processed by the Washington Official Photomail Laboratory, The Pentagon.

USE FOR PHOTO-MAIL ONLY		WAR DEPARTMENT
File:	To:	Date:
Subject:		

W. D., A. G. O. Form No. 968
September 22, 1942
25-47747ABC

Figure 21. WD AGO Form 968.

b. OVERSEA THEATERS. The procedure for handling official photomail in oversea theaters is prescribed by the theater commander in accordance with policies of the Adjutant General's Office.

c. DOCUMENTS AND FORMS. Communications intended for transmission by Official Photomail should be written on WD AGO Forms 968 and 968-1 with inclosures clearly indicated. (See figs. 21 and 22.) These inclosures should not exceed 8½ inches in width or 14 inches in length, however, communications or inclosures

ADDITIONAL SHEETS PHOTO-MAIL ONLY	
File	Subject:
Sheet No. of	(Number)
Do not write above except as indicated	
<div style="background-color: black; width: 200px; height: 20px; margin: 0 auto;"></div>	
<small>W. D. A. G. O. Form No. 968-1 September 23, 1942</small>	

28-47747ABC

TL70346

Figure 22. WD AGO Form 968-1.

smaller than 8½ x 14 inches may be sent by Official Photomail. When it is necessary to use letterhead stationery or forms other than WD AGO Forms 968 or 968-1, the heading OFFICIAL PHOTOMAIL should be prominently typed across the top of each page.

d. **CLASSIFIED MATERIAL.** Classified documents may be sent by Official Photomail. The material will be prepared and receipts for secret or confidential documents maintained in accordance with AR 380-5, Safeguarding Military Information. No receipt will be given for restricted or unclassified matter.

84. Disposition of Official Photomail Film

Official photomail film will be retained for a period of time specified by the theater commander. Official photomail film must be disposed of in accordance with the policies set forth in AR 380-5, Safeguarding Military Information.

85. Disposition of Official Photomail Documents

Originals of official photomail documents will be retained until receipt of the corresponding film rolls is acknowledged by the receiving station. This receipt will be a signed letter form of receipt. The original documents will then be returned to the sender.

Section III. SIGNAL CORPS V-MAIL LABORATORIES

86. General

The Signal Corps V-mail laboratory performs the technical operations of recording, microfilming, film developing, enlarging, print processing, and inspecting. (See fig. 23.) While the functions of the laboratory are basically operational, it is necessary to maintain several improvised work control forms within the laboratory in order to integrate each operation with the preceding and succeeding ones. These improvised work control forms advise each operator of the various photographic peculiarities and indicate compensation of light intensity and developing which must be accomplished, and maintain proper records of laboratory activities. The design of the forms may differ slightly from one laboratory to another, but the purpose of the various styles is similar.

87. Message Center

The message center of each V-mail laboratory is charged with the receipt and transmission of all work passing through the Signal Corps V-mail laboratory and the maintenance of laboratory activity records. It is the responsibility of the message center clerk

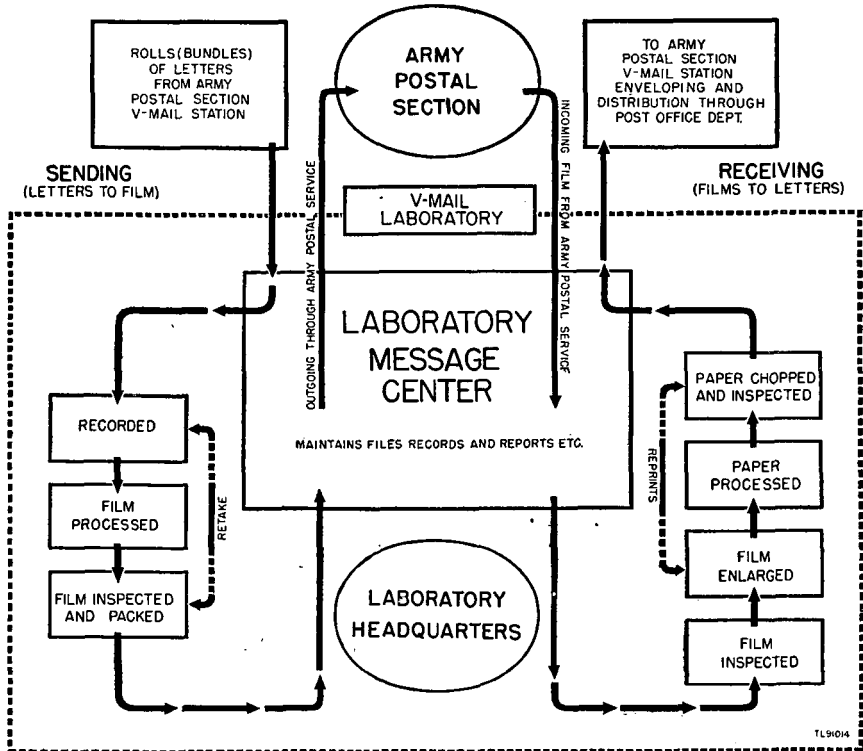

Figure 23. Laboratory message center flow chart.

to maintain neat, orderly, and complete records. Message center and interdepartmental forms are discussed in paragraphs 88 through 92.

88. Logbooks

A logbook comprises *sending log sheets* and *receiving log sheets* and is the permanent record of all laboratory activities. The sending sheets list the roll numbers, when the letters were received, the dates the resulting rolls of film were forwarded and the original letters returned, and any other miscellaneous information that may be necessary. (See fig. 24.) The receiving log sheets list the roll numbers, date and time received, the date and time the prints were forwarded, reprint data, and other miscellaneous information. (See fig. 25.)

89. Work Sheets

At the start of each sequence of operation, whether sending or receiving, one work sheet is assigned to each roll of original letters or processed film.

a. **SENDING WORK SHEET.** During the sequence of sending operations from the roll of original letters through to the satisfac-

torily processed film, technical information describing each step and the operators' names are entered on the sending work sheet. (See fig. 26.)

SENDING WORK SHEET	
Roll No.
DTG
Retakes from Roll No.
<hr/> <hr/>	
Photographed by
Machine No.
Developed by
Density
Inspected by
No. Retakes
Film Faults
Remarks Over ()

Figure 26. Message center sending work sheet.

b. RECEIVING WORK SHEET. During the sequence of receiving operations from the roll of processed film through to the finished facsimile, the proper receiving data is entered on the receiving work sheet. (See fig. 27.)

RECEIVING WORK SHEET	
Roll No.
DTG
<hr/>	
Charted by
Foot Candles
Printed by
No. of Pieces
Pieces Assembled
Inspected by
No. Bad
Chopped by
Remarks Over ()

Figure 27. Message center receiving work sheet.

DATE _____

ROLL NO. _____

MACHINE NO. _____

●

TL 9420

Figure 28. Machine identification target.

90. Machine Identification Target

The message center clerk enters the roll number on the machine identification target. (See fig. 28.) When a roll of original letters is sent from the message center to the recorder operator, the machine identification target is placed at the beginning of the roll.

FROM
ROLL NO. _____

RETAKES
from
PREVIOUS
ROLLS _____

TL 91025

Figure 29. Retake target.

91. Retake Target

Occasionally, after the letters have been recorded and returned to the message center, a retake is necessary. When this occurs, a retake target is placed at the beginning of the group of letters which have to be retaken. The retake target (fig. 29) is filled in with the roll number for which the retakes are needed.

92. Official Photomail

a. **RECEIPTS.** When official mail is received by the laboratory, a proper exchange of classified document receipts must be made in accordance with the provisions of AR 380-5, Safeguarding Military Information.

b. **LABORATORY LOG.** The laboratory must maintain a complete and permanent logbook covering all official photomail operations. These logs are discussed in paragraphs 95 and 96.

Section IV. MESSAGE CENTER PROCEDURES

93. V-Mail Sending

a. **MESSAGE CENTER FUNCTIONS.** On receipt of V-mail letters from the Army postal section, the following functions (fig. 23) are performed by message center:

(1) The roll number, time and date received, and name of person receiving the roll are entered on the sending log. The roll number and time and date are entered on the sending work sheet.

(a) The roll number is made up of three parts: Identification code letter for the sending station, serial number of the roll, and identification code letters for the receiving station. Thus, the first roll sent to station XY by station AB would be marked AB-1-XY.

(b) Time and date received are entered under DTG (date-time group) column. The first two digits indicate the date and the last four the time in the 24-hour system.

(2) The sending work sheet is inserted in an empty film carton and both are forwarded with the roll of letters to the recorder for microfilming.

(3) After recording, the roll of original letters is returned to message center. The message center will hold the original letters until the processed film with the accompanying sending work sheet is returned.

(4) On receipt of the film and the sending work sheet, the message center enters time and date of dispatch, the name of the dispatcher, and the number of images contained in the roll on the sending work sheet. The time and date of dispatch and the number of images contained in the film roll are entered on the film carton. The carton of processed film is returned to the Army postal V-mail section.

(5) At the first convenient opportunity, the information on the sending work sheet is transferred to the permanent sending logbook. The sending work sheet is then filed in the dead file.

b. **RETAKE PROCEDURE.** In some instances, the production of microfilm frames in the sending station will not be satisfactory, and will necessitate a retake. The retake request originates during film inspection and is normally indicated on the sending work sheet and on the retake sheet. (See fig. 30.) Both the retake sheet and the sending work sheet are forwarded with the processed film to message center. The message center continues to hold the roll of original letters but not the roll of film, until retakes are all sat-

isfactorily processed and returned. The message center procedure in handling retake requests is as follows :

(1) The message center files the sending work sheet in the live file and pulls out from the original roll of letters those letters listed in the request.

(2) A retake target (fig. 29), to which the information from the request sheet has been transferred, is placed at the beginning of the original retake letters.

(3) The retake target and the retake letters are added to the end of the next roll of V-mail letters being forwarded to the same receiving station. When this new roll is forwarded to the recorder, it consists of the start target, letters, retake target, and retake letters; and is accompanied by the retake sheet.

(4) The new roll is recorded and returned to message center, where the retake letters are taken from this roll and placed in the roll of letters from which they were originally withdrawn.

(5) The retake sheet is attached to the original sending work sheet to offer proof that all letters in the roll have been micro-filmed satisfactorily. Both retake and sending work sheets are then filed by roll number in the dead file.

RETAKES		
Original Roll No.....		
Shipped on Roll No.....		
Date		
Sheet.....	of	
Addressee	Veeder	Key Words
.....		
.....		
.....		
.....		
.....		
.....		

Figure 30. Retake sheet.

94. V-Mail Receiving

a. PROCEDURE. The laboratory message center handles film received from the Army postal section in the following manner:

(1) The film roll number, time and date received, the number of images on the roll, and the name of the person receiving the film are entered on the receiving log sheet. The film roll number and time and date received are entered on the receiving work sheet.

(2) After the entries have been made, the film is delivered to the charting room with the receiving work sheet where it is inspected. The inspector passes the roll with the work sheet on for printing and processing.

(3) The film roll is enlarged, and the resulting enlarged letter facsimiles together with the film and work sheet, are delivered by the chopper operator to message center.

(4) The processed letter facsimiles are dispatched to the Army postal section for delivery after the message center clerk enters the date and time dispatched and his signature on the receiving log sheet. If no reprint or reduction request accompanies the roll of film, it is dispatched to the Army postal section along with the letter facsimiles.

(5) The receiving work sheet is then filed by roll number in the dead file.

b. REPRINT REQUESTS. When a reprint request accompanies a roll of film, the procedure for handling will be as follows:

(1) The receiving work sheet will be filed in the live file.

(2) The roll of film and the reprint sheet (fig. 31) is delivered to the reprint department, which reprints and processes the necessary negatives and returns the roll of film, reprints, and the reprint sheet to message center.

(3) The message center clerk dispatches the reprints to the Army postal section and enters the time and date of dispatch, the quantity of reprints, and the messenger's name on the receiving log. The reprint sheet and the receiving work sheet are attached and filed in the dead file.

d. **RETAKE REQUESTS.** In rare instances, it may be necessary for a receiving laboratory to request a retake of a letter from a sending laboratory.

(1) When the inspector discovers a facsimile which must be rephotographed, it is cut out of the roll of letter facsimiles and the roll number and veeder count are written on the reverse side. A retake request, WD AGO Form 949 (fig. 22) will be initiated and completed by the inspector and presented to the message center clerk who checks the entries on this form for completeness and forwards the form to the Army postal section.

(2) If the addressee's name and address are obliterated on the print, the addressee's name from the preceding letter is shown on the retake sheet with the words "letter after".

(3) A separate form is prepared for each station from which retakes are requested. If the facsimile has been cut from the roll, it is forwarded with the form.

95. Official Photomail Sending

a. **PREPARATION.** (1) *General.* Official documents are received by the laboratory message center clerk through the Army Courier Service from the Army postal section. After reading and acting on any special instructions forwarded with the documents, the message center clerk prepares the documents for work by removing all clips and staples, and numbers each sheet consecutively starting with the number 1 for each film roll.

(2) *Target number and form.* The message center clerk assigns a target number (film roll number described in par. 72). He initiates the target number form (fig. 33) by entering the target number, date filmed, number of sheets, and film destination. This target number form always contains the symbol "(OPM)" in large black letters, and a printed request for a written acknowledgment of the receipt of the film roll by the receiving station.

OFFICIAL PHOTOMAIL

W _____ **(OPM)**

NUMBER _____ CODE

DATE _____

NO. OF DOCUMENTS _____

DESTINATION _____

APO

REQUEST THIS FILM BE
ACKNOWLEDGED IMMEDIATELY
BY OFFICIAL PHOTOMAIL

OFFICIAL PHOTOMAIL STATION
I-C-356 PENTAGON BUILDING
WASHINGTON, 25, D. C

AP-SC Form No. 36
20 June 1964

24-75881AB 1W

TL70344

Figure 33. Target number form.

(3) *Work sheet.* The work sheet (fig. 34) is initiated by the message center clerk who enters the target number (film roll number), date and time the original documents were received, signature of receiving clerk, number of sheets, classifications, and any special instructions.

SENDING WORK SHEET		TARGET NUMBER	
RECEIVED BY	PROCESSED BY		
HOOR AND DATE	TIME		
NO. OF IMAGES	DENSITY		
RECORDED BY	DISPATCHED BY		
RECORDER NO.	HOUR AND DATE		
SPECIAL INSTRUCTIONS			

Figure 34. Sending work sheet.

(4) *Sending log sheet.* The permanent laboratory record of information regarding each target number is contained in the sending log. (See fig. 35.) The message center clerk enters the following data on the log: Target number (film roll number), date and time the original documents were received, classification of document, number of sheets, originating agencies, date filmed, recording operator's symbol, recording machine number, exposure factor, resulting film roll density, film processor's symbol, time and date film was dispatched, and the date the film receipt acknowledgment was received.

b. **DISPOSITION.** (1) *Target form and work sheet.* After dispatch of the film, the message center clerk separates the target number form and work sheet from the original documents. The work sheet is stapled to the target number form and both are filed as a permanent laboratory record in support of the sending log.

(2) *Original documents.* After the dispatch of the film roll, the original documents are normally filed by target number in accordance with the provisions of AR 380-5. In cases where special instructions require the immediate return of the original documents to the initiating agency, they are returned through the Army postal section. The laboratory, however, retains a full record of these documents. In normal cases when the receipt of the film is acknowledged by the receiving station, the original documents on such a roll are returned to the initiating agency through the Army postal section. (This procedure is also discussed in par. 85.)

c. **RETAKES.** The official photomail retake procedure is similar to that used in V-mail operation.

96. Official Photomail Receiving

a. **GENERAL.** Official photomail receiving is similar to V-mail receiving except in the use of retake requests, log sheets, and work sheets.

b. **RETAKE REQUESTS.** Form No. 949 is not used in requesting official photomail retakes. Such requests are forwarded to the sending station by the most expeditious means.

c. **RECEIVING LOG.** The receiving log (fig. 36) is a permanent laboratory record of official photomail receiving operations. The message center clerk will prepare this log sheet by entering the film number, Army Courier Service number, target date, date film was received, number of images, film density, date printed, print processor's symbol, date prints are dispatched, print destination (document addressee), dispatching clerk's symbol, date receipt of prints was acknowledged.

d. RECEIVING WORK SHEET. The receiving work sheet (fig. 37) is prepared by the message center clerk by entering the roll numbers, number of images, film density, special instructions, classification, date and time received, and the receiving clerk's signature.

ROLL NO.	RECEIVING WORK SHEET
RECEIVING DATA	
.....	
No. Images.....	Density.....
Spec. Instr.	
.....	
Rec'd.....	Hour..... By.....
.....PRINTING	
.....	
Voltage.....	Lens Stop.....
No. Rolls.....	Incl. Nos.....
Operator	
.....	
.....PROCESSING	
Time..... Operator.....	
.....	
DRYING AND SORTING	
Reprints	
.....	
..... Requested by.....	
DISPATCH	
Date..... Hour..... By.....	

Figure 37. Receiving work sheet.

97. Dispatch of Short Film Strips

It is unlikely that a sending V-mail station would have a sufficient quantity of official photomail at one time to fill a normal size film roll. Since official documents must be forwarded as quickly as possible, they are recorded on short film strips and dispatched in small pillbox containers which in turn are sealed in a cloth mailing bag. The box should be reinforced by inserting a wooden core or similar material, and the cover made secure by taping. The inclosed film strip density should be written in pencil on the inside of the box. The outside cover of the pillbox should be marked with the roll number and the classification. The cloth bag should be marked with the roll number only. The tag attached to the cloth bag should be marked with the sending station's return address and the mailing address of the station to which the bag is being sent.

Section V. SENDING DEPARTMENT

98. Recording

a. GENERAL. Efficient operation of a V-mail laboratory requires the determination of correct exposures at the start of operations. It is important that variations in exposure be corrected to produce satisfactory prints.

b. TARGETS. For the purpose of determining correct exposures, density and count targets are recorded on each roll of film. The operator first records the machine identification target which was assigned immediately following the last letter of the normal roll. This target is followed by the retake letters, the finish target, and the end target. When WD AGO Form 949 is used the same procedure is followed. Next the *start target* (fig. 38) is recorded, followed by a density target and 100 letters. A veeder count target, a few inches longer than a V-mail letter form, is placed on the back of the first of every 100 letters beginning with the 101st letter. This will enable the number on the bottom and overlapping part of the count target to be recorded. Three density targets (usually white sheets of paper) are recorded with each roll of film: one at the beginning of the film roll, one in the center, and a third at the end, immediately before the last letter. A finish target (fig. 39) will be recorded to indicate the completion of a roll of original letters. An end target (fig. 40) will be recorded to indicate the end of the roll of film. If retakes are included in the roll, a retake target (fig. 29) is recorded in front of them.

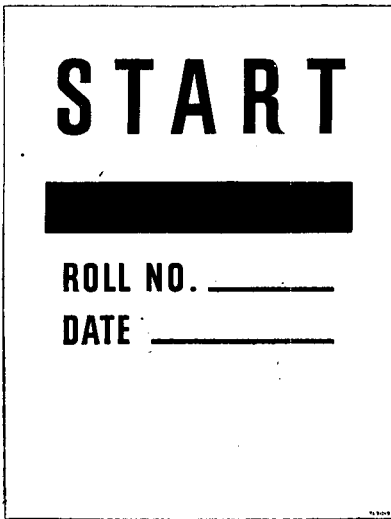

Figure 38. Start target.

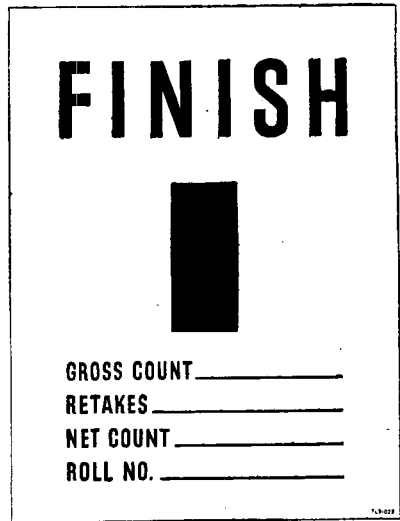

Figure 39. Finish target.

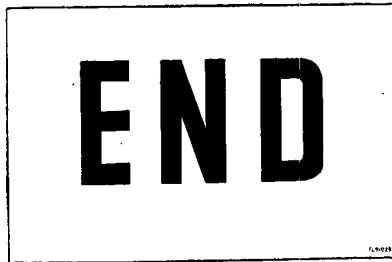

Figure 40. End target.

c. PURPOSE OF TARGETS. The purpose of using targets is as follows:

(1) A microfilm frame of the density target establishes the proper printing exposure.

(2) The veeder count target (fig. 41) identifies any letters which might have to be located for retakes.

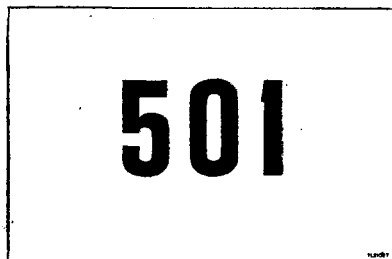

Figure 41. Visible portion of veeder count target.

(3) The retake target indicates to the message center or a receiving station the letters included and the number of the original roll for which the retakes are recorded.

(4) A *repeat of previous document* target (fig. 42) is used to indicate that a document has been faultily recorded preceding the target and that it is being recorded again following the target.

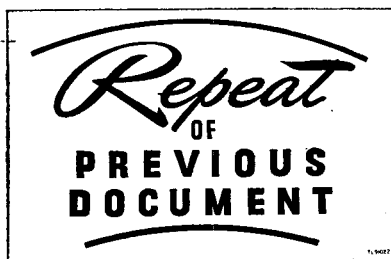

Figure 42. *Repeat of previous document target.*

d. EXPOSURE. By using a recorder, a roll of original letters is exposed on a 100-foot roll of 16-mm film. The recorder is so constructed that only one adjustment is required to obtain proper photographic reproduction. This adjustment consists of varying the light intensity when necessary. The operator passes the letters into the recorder singly in a rapid sequence until the roll of original letters has been recorded.

e. FINAL PROCEDURE. The recorder operations are entered on the sending work sheet. The roll of exposed, undeveloped film and the work sheet are inserted in a film carton. The roll number is marked on the outside of the box. The roll of original letters is returned to the message center, and the film carton with its contents is forwarded to the film processor.

99. Film Developing

a. DEVELOPING DEVICES. Normally, the developing of exposed microfilm is accomplished on a continuous developer, which is an automatic processing unit. For small quantities of film, a reel developer may be used. V-mail stations are equipped with both types of units.

b. PROCEDURE. The film processor receives the exposed film and the sending work sheet. He processes the film, enters operational data on the sending work sheet, and forwards both to the film inspector.

100. Film Inspection

a. FILM DEFECTS. Film inspection requires a knowledge of the causes of film defects and proper corrective measures. Film de-

fects may be caused by improper handling, recording, or developing. It may be advisable to make a chart of all known defects as they come to the inspector's attention. This chart can be referred to when necessary and prevents incorrect decisions and loss of valuable time. Rigid inspection is essential at a sending laboratory to avoid retake requests from a receiving laboratory.

b. **READING DEVICES.** Careful inspection requires two separate operations: the checking of each individual microfilm frame with a reading device, and the taking of densitometer readings of three recorded density targets. A densitometer measures transmitted light and is usually the first operation. If film is too dark or too light, a retake of the whole or part of the film may be requested by the inspector. The reading operation consists of viewing an enlarged 11- by 14-inch image of each negative projected in sequence on a translucent screen. Defects can be seen easily at this magnification.

c. **MARKING DEFECTS.** When defects appear in a film image, the inspector punches a hole in the faulty negative and lists it on a retake request form. The retake request is forwarded to the message center with the roll of inspected film.

101. Recording Official Photomail

a. **GENERAL.** Normally, official mail received for recording will be photographed on a recorder. Odd-size or highly detailed documents may be photographed on either 16- or 35-mm film in a microfilm camera.

b. **ODD-SIZE DOCUMENTS.** In each case where odd-size documents are received with normal size work, these odd-size sheets are withdrawn from the normal work. Where an odd-size document is withdrawn from normal work, an insert sheet (a local form) should replace such withdrawn documents. The following statement should appear on an insert sheet: "Document(s) from this space will be found at the end of this roll." In any case where an odd-size document appears at the end of a roll, the end target will follow such odd-size documents and the target number form. In all cases the target number form will precede and follow all original documents.

c. **OTHER PROCEDURES.** Other official photomail processing procedures are the same as in V-mail.

Section VI. RECEIVING DEPARTMENT

102. Film Charting

Film charting is the process of analyzing density or light stopping power of photomail negatives. The purpose of charting is to

determine the correct voltage and aperture settings required by the enlarger operator.

a. **DENSITOMETER READINGS.** When a densitometer is used, readings are taken approximately at 10-foot intervals. If density ranges vary to an extreme degree, readings may be taken at 5-foot intervals. Readings are marked on the receiving work sheet accompanying the roll of film.

b. **FILM CHARTING METER READING.** A film charting meter scans the average amount of light transmitted through a roll of film at any given portion. The length of film is passed over an opening where the blackness of the passing area is registered in foot candles. Foot-candle readings are taken at 10-foot intervals and are entered on the work sheet.

c. **RETAKE REQUEST.** The film inspector will indicate a retake request for any part of the film which is damaged or too light or dark to produce a legible facsimile when printed.

d. **TRANSMITTAL.** The roll of film is forwarded to the printer operator with the receiving work sheet.

103. Enlarging

a. **IDENTIFICATION OF PRINTS.** Before enlarging, the operator will mark the correct roll number at the start of each roll. Reprints will be identified by marking the reprint number in the corner of each reprint.

b. **EQUIPMENT.** A continuous enlarger is used for routine enlarging of 16-mm film. This enlarger incorporates a mechanism which synchronizes the speed of the film through the enlarger with the speed of the paper passing over the copy plate below it. If a roll of film should have too much density variation, the film should be exposed for the best average density. If there are extreme changes in density, the voltage or stop openings should be adjusted to produce the best results with each density. Reprints are exposed on a hand-operated Model N enlarger with a cutting arm which cuts a single reprint or a short series of reprints from a roll of paper after it has been exposed.

c. **TRANSMITTAL.** The enlarging operator enters operational data on the work sheet and forwards the exposed, undeveloped paper roll and the work sheet to the processor. The roll of film is forwarded to the inspector.

104. Paper Processing

a. **EQUIPMENT.** Paper processing is accomplished on a continuous developer, an automatic developing unit consisting of a series of separate tanks and a drier. The exposed paper is fed into the machine singly and comes out completely developed, dried, and ready for inspection and chopping.

b. **PRIORITY.** Paper rolls will be processed as nearly as practicable in numerical sequence and length of time they have remained in the laboratory.

105. Print Inspection

Print inspection is the last important operation in the V-mail laboratory and must be complete and thorough. The purpose of the inspection is not only to check for legibility and completeness of text but also to obtain corrective information in order to avoid repetition of faulty prints. Letters which cannot pass the legibility and completeness test must be reprinted, reduced, or retaken, depending upon the cause of the fault. The discussion of actual print inspection and function is discussed in paragraphs 106 through 113.

106. Preparation to Start Work

a. **LOCATION.** Paper inspection is done in a well-lighted room, located as conveniently as possible to the message center.

b. **SUPPLIES.** Before starting to work, the inspector should have the following supplies on hand: reprint and reduction sheets, work box to hold film, white chalk, and heavy black or grease pencil.

107. Actual Operation

a. **GENERAL.** The processed paper is received from the paper processing room, and the film used to expose the roll will be delivered from the continuous enlarging department. No paper will be inspected until both paper and the corresponding roll of film are on hand.

b. **INSPECTION.** To inspect prints, two rewind spindles are clamped about 4 feet apart on a table or bench. (See fig. 8.) The processed facsimiles are placed on the spindles with the printed side facing up. Before the actual inspection is begun, the inspector will compare the roll target number with the number of the work sheet to make sure they are identical. The work sheet is inspected to determine whether the entire roll of film was printed in two or more pieces or one complete roll of paper. If the roll was printed in two or more pieces, the inspector will make certain that all pieces are on hand before beginning. The paper is wound from one spindle to the other at a speed which allows careful scanning of each print without reading each word. With practice, an operator can learn to scan a roll of letters in a short period of time.

c. **PRINT DEFECTS.** When defects impair the legibility of the print, it must be reprinted, reduced, or retaken. When a fault is obvious but does not affect the legibility, the inspector should pass the print and notify the operator at the source of the fault in order

that corrective measures can be applied.

108. Reprints

Letters requiring reprinting will be marked with a heavy black X on the face of the defective print so that they may be later identified and removed. When the roll has been inspected, the reprints will be counted and marked on both the receiving work sheet and the reprint sheet. Some of the print defects which an operator may discover are as follows:

a. **OVERLAPS.** Where one letter overlaps the preceding one, the recorder was fed too quickly, or the corners of the original letter were folded over accidentally during the recording process.

b. **STREAKS.** Streaks are caused by scratched film, chemical stains, or burned-out light bulbs in the recorder.

c. **WAVY LINES.** Alternate light and dark lines across a print are caused by mechanical trouble in the recorder or enlarger, or severe voltage fluctuation.

d. **UNDEREXPOSURE AND OVEREXPOSURE.** Improper voltage settings or aperture settings on the continuous enlarger cause underexposure or overexposure. Improper illumination in the recorder is another cause.

e. **LETTER EDGES OR CORNERS CUT OFF.** These defects are caused when original letters are fed into the recorder at an angle.

f. **IMPROPER OR IRREGULAR SPACING.** The result of mechanical trouble in the recorder, causing running of film between the feeding of letters. Film as well as paper is wasted.

g. **SPLICES.** Letters falling across a splice must be reprinted.

h. **STRETCH.** The print image is distorted by stretching, caused by slipping film or absence of synchronization between the speed of paper and film on the continuous enlarger or recorder.

i. **FAULTY PAPER.** When paper is accidentally exposed to light, the exposed portions will be dark.

j. **REVERSED IMAGE.** Improper threading of film on continuous enlarger causes reversed images.

109. Prints to be Reduced

A letter facsimile requiring reduction will be marked with a white chalk mark on the upper left-hand corner. The letter facsimile is then turned face down so that the roll number and the last veeper count number are marked in pencil (one above the other) on the back of the letter. Each letter to be reduced will be tallied on a reduction sheet. The process of reduction will be discussed in paragraph 113.

110. Completion of Inspection

After inspecting the complete roll, the film and reprint sheet are

sent to the reprint department. The work sheet and the roll of letters are sent to the chopper operator. When the reprints and reductions have been completed, the inspector will inspect each group of prints before sending them to the message center.

III. Chopping

a. GENERAL. When a roll of V-mail prints has been completely processed and inspected, it must be chopped into individual letter facsimiles. This is the duty of the paper chopper. The handling of defective letters and uniformity in size are of great importance. Uniformity of size is especially important. The letters are inserted into envelopes by automatic machines operated by the Army postal section. Letters which are either too large or too small are liable to be damaged in the machines and a reprint must be made. The letter will be returned to the V-mail laboratory marked only with the roll number, and a tedious search is required to find the letter.

b. PREPARATION FOR CHOPPING. Prior to chopping, the printed roll of facsimiles must be wound so that the end target is at the beginning of the roll. The letters will then fall in sequence as they are chopped. The roll is placed in the chopper with the facsimiles face up. Two boxes should be placed on top of the table to hold reductions and reprints.

c. CHOPPING INSPECTION. The chopping operator will scan all letter facsimiles to make certain that no defective prints are missed. All letter facsimiles marked for reduction or reprinting will be placed in their respective boxes. After inspection, the reductions and reprints are counted and checked against the work sheets. The completed roll of chopped prints is securely tied, the roll target on top, and sent to the message center with the work sheet.

d. REPRINTS FROM PREVIOUS ROLLS. The chopper may find reprints at the end of the roll. Reprints are chopped in the regular manner and set aside while the roll is being chopped. The reprint target is placed on top of the reprint pile and the bundle is tied and forwarded to the message center.

III.2. Identifying Film for Reprints

It is necessary for the inspector to know whether a defective print was caused by the film image in order to decide whether a retake request or a reprint request be initiated. The inspector must analyze those portions of the film which correspond to the defective prints.

a. LOCATING FAULTY PRINTS. The images of faulty prints are located on a device known as an inspection projector. (See fig. 7.) When an image has been located, it is marked by placing two thin strips of tape across the film, above and below the image. Care must be exercised when taping to prevent obscuring any part of

the image to be reprinted. *Place the tape on the film base, not the emulsion.* Another method of marking is to tie a piece of thread, through a perforation, to the edge of the film approximately at the middle of the image. A number of consecutive images to be reprinted may be identified by marking the leading edge of the first image and the trailing edge of the last image in the sequence.

b. **RETAKES.** If the film image caused the defective print, the original letter must be retaken. In this instance, the inspector initiates a retake request, staples the faulty print to the request and forwards both to the message center which, in turn, forwards the request and print to the Army postal section.

c. **REPRINTS.** When the film image does not contain the fault evident on the corresponding print, that part of the film which must be reprinted is marked off for the printer. The marked roll of the film, the reprint sheet stapled to the faulty print, and the completed receiving work sheet are forwarded to message center.

113. Reduction System

Reduction is a process of treating overexposed prints to increase legibility by passing them through a series of chemical baths. The reduction system is recommended when it is advantageous to avoid a large number of reprints caused by overexposure. The overexposed facsimiles are lightened to a level at which writing is clearly legible. In no instance should prints be reduced to a degree which destroys the legibility of the facsimile.

a. **ENLARGING FOR REDUCTION.** When the enlarging operator receives a roll of film with facsimiles which must be reduced, he studies the chart which accompanies the roll of film and sets the voltage and aperture of the enlarger to correctly expose the blackest part of the film. If the chart indicates a wide range of densities between the lightest and darkest parts of the film roll, it may be necessary to adjust exposure during printing.

b. **STRAIGHT REDUCTION.** (1) Straight reduction may be accomplished by placing large trays containing hypo at each chopping table. As the chopper encounters a print that is overexposed, the roll number and count target number are marked on the back of the print and then the print is immersed in one of the hypo trays. The chopper can readily pick out those prints marked for reduction.

(2) A separate tray is used for each group of prints following a count target. In all subsequent steps each group of prints is kept separately.

(3) At hourly intervals or other suitably designated intervals, the chemical mix-man transfers dark prints from hypo trays to a pail one-third full of hypo. The mix-man will then carry the pail to the room used for reducing. The prints are handled in this manner since they must be hypo-soaked when immersed in the reducer.

(4) Prints are placed face up into the reducing agent. The length of time they are immersed depends upon the amount of reduction required and the strength of the reducing agent. When prints have reached a satisfactory contrast, they are taken out and immersed in the final hypo. Since prints tend to continue reducing in final hypo, they must be removed from the reducer prematurely.

Caution: Reducer reacts with iron to form a troublesome intense blue precipitate which may stain the prints. Enameled or porcelain tanks and pails must be free from chips and cracks.

(5) Prints in the final hypo pail should be agitated when immersed. After the initial agitation, prints remain in the hypo pail until ready for washing.

(6) Reduced and fixed prints are thoroughly washed, dried, sorted, and forwarded to the message center.

c. BLEACHING. (1) The bleaching process requires three trays. Trays are placed in a row on a bench. The first tray contains bleach, the second hypo, and the third contains water for rinsing.

(2) Prints are immersed in the bleaching solution which converts some of the silver in the image to silver bromide. The length of time required for the bleaching process depends upon the intensity of the print and the strength of the bleaching solution. The bleaching process may vary from $\frac{1}{2}$ to 2 minutes at a similar degree of temperature. When prints appear to have almost reached the required contrast, they are removed and immersed in the hypo without rinsing. Bleaching solution should be changed when it turns blue, otherwise prints will reduce to brown instead of black.

(3) Fixing requires 2 minutes immersion in hypo at a temperature of 70°F. Fresh hypo should be added every 4 hours under normal conditions, or whenever prints show a tendency to become brown in color.

(4) After fixing, prints are placed in the tray containing the rinse to await thorough washing, drying, sorting, and forwarding to the message center.

114. Official Photomail

a. EQUIPMENT. Official photomail is usually specified for enlargement to original document size. The equipment used for enlarging official photomail depends upon the size and length of film and the enlarging specifications.

b. ENLARGING. In enlarging 35-mm film a Model A enlarger is used. A continuous enlarger is used to print 16-mm film whenever possible. However, a short strip of 16-mm film not containing enough images to justify continuous processing is enlarged on a Model 10 reader. (See fig. 11.)

INDEX

	Paragraph	Page
Acknowledgment of receipt.....	77	40
Actual operation, inspection.....	107	68
Allocation of personnel, operations.....	22	9
Allocation of personnel, training.....	69	34
Army coordinating agencies.....	13	4
Army postal service, operational responsibility.....	7	2
Assignment.....	10	3
Assistant chief processor, duties:		
Receiving.....	52b	27
Sending.....	52a	27
Augmentation teams.....	14e	6
Basic photography.....	35	13
Basic technical training.....	34	12
Bleaching, reduction.....	113c	72
Buildings, laboratory.....	20	8
Bundling.....	73	36
Care of equipment.....	30	11
Censorship.....	9	3
Charter operator, duties:		
Class A.....	55a	28
Class B.....	55b	28
Chemical mixer, duties.....	58	30
Chemical mixing, operation.....	20c	8
Chief darkroom operator, duties:		
Receiving.....	53b	28
Sending.....	53a	28
Chief processor, duties.....	51	27
Choosing chief processors.....	48	26
Chopping.....	111	70
Chopping inspection.....	111c	70
Chopping, preparation.....	111b	70
Code designations, Army postal section.....	71a	36
Completion of inspection.....	110	70
Conservation of photographic material.....	31	12
Continuous enlarger operator, duties:		
Class A.....	54a	28
Class B.....	54b	28
Continuous enlarger, training.....	43	21
Continuous film processing.....	36	13
Continuous paper processing operator, duties:		
Class A.....	56a	29
Class B.....	56b	29
Class C.....	56c	29
Class D.....	56d	29
Darkrooms.....	20a	8
Definitions:		
Official photomail.....	2c	1
Photomail.....	2a	1
V-mail.....	2b	1
Delivery assurance, V-mail.....	4b	2
Densitometer readings.....	102a	67
Destruction of letters.....	81	40
Detachment headquarters, V-mail.....	14a	5
Dispatch of short film strips.....	97	63
Electricity.....	19	7
Enlarging:		
Training.....	40	19
Equipment.....	103b	67
Identification of prints.....	103a	67
Transmittal.....	103c	67
Enlarging for reduction.....	113a	71
Exposure, recording.....	98d	65

	<i>Paragraph</i>	<i>Page</i>
Faulty paper	108 <i>i</i>	69
Film:		
Charting	102	66
Developing	99	65
Disposition	82	40
Inspection	38, 100	16, 65
Film defects	100 <i>a</i>	65
Marking defects	100 <i>c</i>	66
Reading devices	100 <i>b</i>	66
Inspector, duties:		
Class A	61 <i>a</i>	31
Class B	61 <i>b</i>	31
Loading, training	36 <i>b</i> (2)	14
Processing	42	21
Processor (continuous), duties:		
Class A	60 <i>a</i>	31
Class B	60 <i>b</i>	31
Processor (reel), duties.....	59	30
Splicing, training	36 <i>b</i> (1)	13
Film charting meter reading.....	102 <i>b</i>	67
Final team training.....	50	27
Folding, inserting, delivery, V-mail facsimiles.....	78	40
Identifying film for reprints.....	112	70
Improper or irregular spacing, defect.....	108 <i>f</i>	69
Individual technical training.....	28	11
Inspection, prints	107 <i>b</i>	68
Introduction, training	23	10
Laboratory signs and waste.....	21	9
Laboratory technician, V-mail or microfilm.....	33 <i>a</i>	12
Letter edges or corners cut off, defect.....	108 <i>e</i>	69
Locating faulty prints.....	112 <i>a</i>	70
Logbooks, sending and receiving log sheets.....	88	45
Machine identification target.....	90	50
Message center	20 <i>d</i> , 87	9, 44
Clerks, duties:		
Class A	63 <i>a</i>	32
Class B (receiving).....	63 <i>c</i>	32
Class B (sending).....	63 <i>b</i>	32
-Functions	93 <i>a</i>	51
Procedure, training	45	22
Mess teams	14 <i>b</i>	6
Microfile operator, duties:		
Class A	67 <i>a</i>	33
Class B	67 <i>b</i>	33
Class C	67 <i>c</i>	33
Class D	67 <i>d</i>	33
Microfile operation, training.....	39	19
Microfilm:		
Equipment repairman	33 <i>b</i>	12
Equipment repairman, duties.....	62	31
Model C-1 recorder operation, training.....	37	15
Model N enlarger, training.....	44	22
Objective, training	24	10
Odd-size documents, official.....	101 <i>b</i>	66
Official attitude, V-mail.....	4 <i>a</i>	1
Official photomail:		
Classified material	83 <i>d</i>	42
Continental United States.....	83 <i>a</i>	42
Disposition of documents.....	85	44
Disposition of film.....	84	44
Enlarging	114 <i>b</i>	73
Equipment	114 <i>a</i>	72
Forms	83 <i>c</i>	43

	<i>Paragraph</i>	<i>Page</i>
Laboratory log	92b	51
Oversea theaters	83b	43
Receipts	92a	50
Receiving	96	60
Sending	95	56
Size of documents	83c	43
Operational responsibility, APS	7	2
Overlaps, defect	108a	69
Paper:		
Chopper operator, duties	66	33
Inspector, duties	65	32
Paper processing:		
Equipment	41a, 104a	20, 67
Priority	104b	68
Photographic (signal) teams	14d	6
Photomail:		
Definition	2a	1
Comparative weight	3a	1
Enlarging	40	19
Installations	15	7
Location requirements	16	7
Organization	12	4
Numbering film rolls	71b	36
Size of facsimiles	3b	1
Technicians	33	12
Postal teams	14c	6
Preparation for final team training	68	33
Preparation to start work	106	68
Print defects	107c, 108	68, 69
Print inspection	105	68
Prints to be reduced	109	69
Production reports, form	70	34
Project work forms	32	12
Purpose and scope	1	1
Purpose of targets, recording	98c	64
Receiving work sheet	89b	49
Recorder operator, duties:		
Class A	64a	32
Class B	64b	32
Recording, official photomail	101	66
Recording, sending department	98	63
Reduction requests, V-mail	94c	54
Reduction system	113	71
References	11	3
Registration, APO V-mail, receiving	76	39
Reprint and reduction, duties:		
Class A operator	57a	29
Class B operator	57b	30
Class C operator	57c	30
Class D operator	57d	30
Reprint requests, V-mail	94b	53
Reprints	108	69
Identifying	112c	71
Retake:		
Procedure, V-mail	93b	51
Requests, V-mail	94d	56
Target	80, 91	40, 50
Retakes:		
Handling requests	79	40
Identifying	112b	71
Official photomail	95c	60
Reversed image, defect	108j	69
Roll numbers	74	37
Rotation of personnel	49	27

	<i>Paragraph</i>	<i>Page</i>
Segregating trainees, team training:		
Group I, paper processing.....	47a	26
Group II, film processing.....	47b	26
Group III, clerical.....	47c	26
Sending flow sheets, description.....	75	37
Sending work sheet.....	89a	45
Signal Corps V-mail laboratories.....	86	44
Sorting original letters.....	72	36
Specialist training, general.....	27	11
Splices, defect.....	108g	69
Standard methods.....	29	11
Start target.....	98b	63
Straight reduction.....	113b	71
Streaks, defect.....	108b	69
Stretch, defect.....	108h	69
Targets, recording.....	98b	63
Team training, general.....	46	26
Technical responsibility, photomail.....	8	2
Training aids and facilities.....	26	10
Training references and guides.....	25	10
Transportation.....	17	7
Underexposure and overexposure.....	108d	69
Use of V-mail.....	4	1
Ventilation.....	20b	8
V-mail:		
Detachments.....	14	4
Forms.....	6	2
Priority.....	5	2
Receiving, message center procedure.....	94	53
Sending, message center procedure.....	93	51
Waste.....	21b	9
Wavy lines, defect.....	108c	69
Water.....	18	7
Work sheets.....	89	45